



## Technical Data Sheet

### PB-Fastener Fixation for wood tiles

#### COMPONENTS

The PB-Fastener is composed of 1 piece.

#### CHARACTERISTICS

Weight: 0,05 kg

To be used only with PB-TABS 6mm

#### MATERIAL

Polyamide (PA-G30 D1)

Designed and manufactured in Europe.

Resistant to weathering, to heat and a wide range of chemicals.

Temperature range: -30 °C to +80 °C

#### PACKAGING

Pieces per carton: 600 pcs

Carton weight: kg

Carton dimension: 400 x 290 x 200 mm

Cartons per pallet: 120 pcs

Pieces per pallet: 72000 pcs

Pallet dimensions: 100x 120 x 220 cm

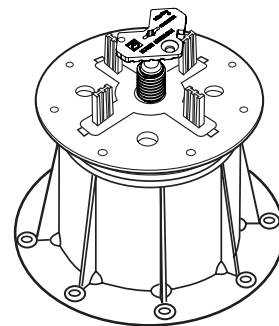
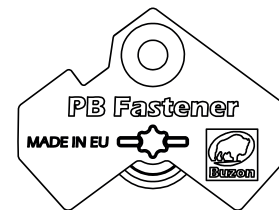
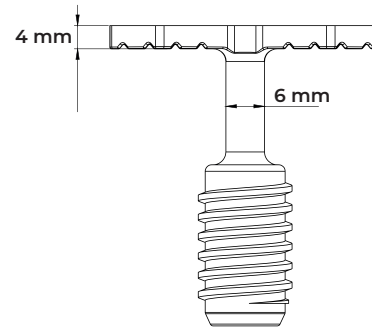

#### APPLICATIONS

Fixation for wood tiles.

This accessory is available for applications with various outdoor finishes, such as granite stone pavers, composite / timber tiles.

#### SAFETY INSTRUCTIONS

Buzon pedestals and accessories are designed to support external raised floors for pedestrian traffic only and are not designed to support or be subjected to moving and/or vibrating machinery & equipment, including maintenance, cleaning vehicles, automobiles and other similar equipment.

