



EASY RAIL SYSTEM

E-BRS-V4

p.1

©copyright, 2024, BUZON PEDESTAL INTERNATIONAL

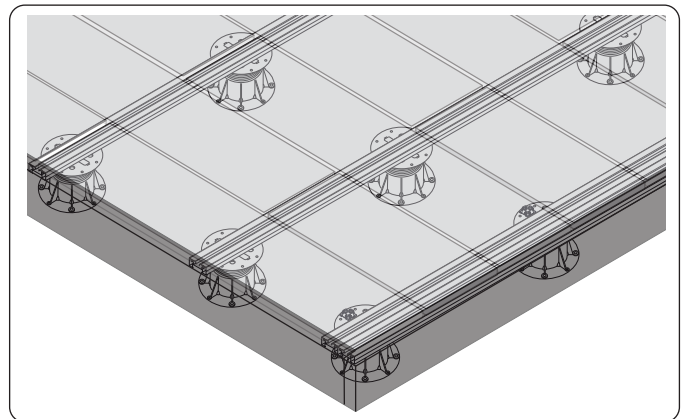
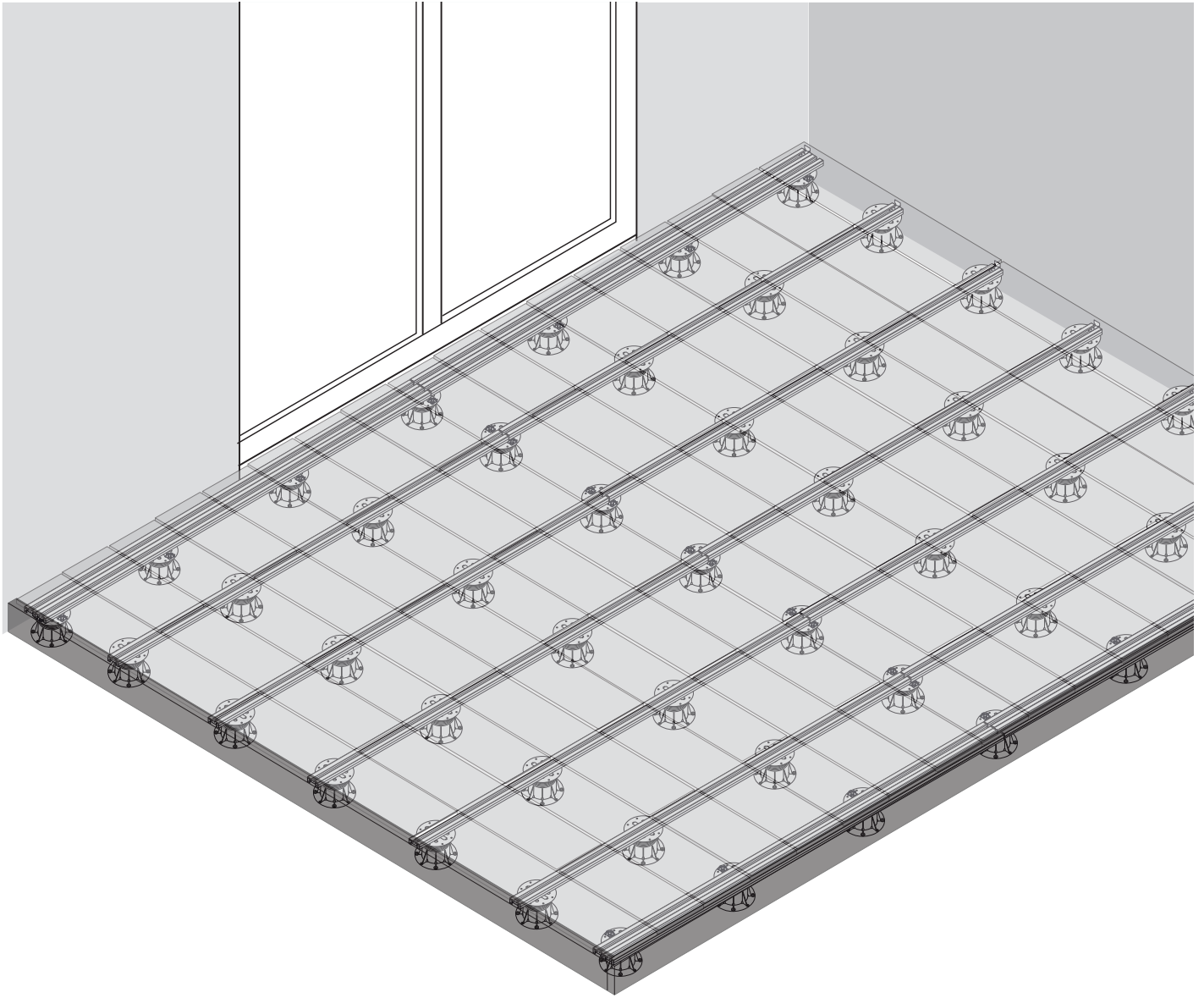

Ref: 62 GNO 71 - Rev.1 - 24/06/2024

The content of this document is not contractual and constitutes only a suggestion of use. Subject to error, omission or modification.

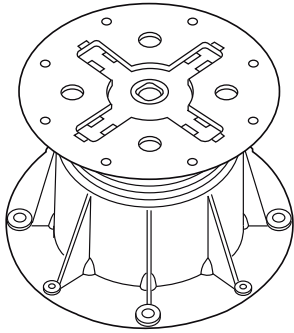

Plot PB-Series

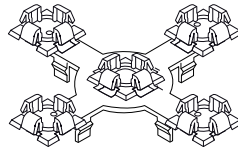

PB-KIT-2

U-BRS-VIS

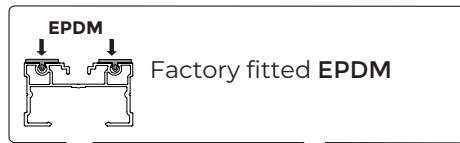

Factory fitted EPDM

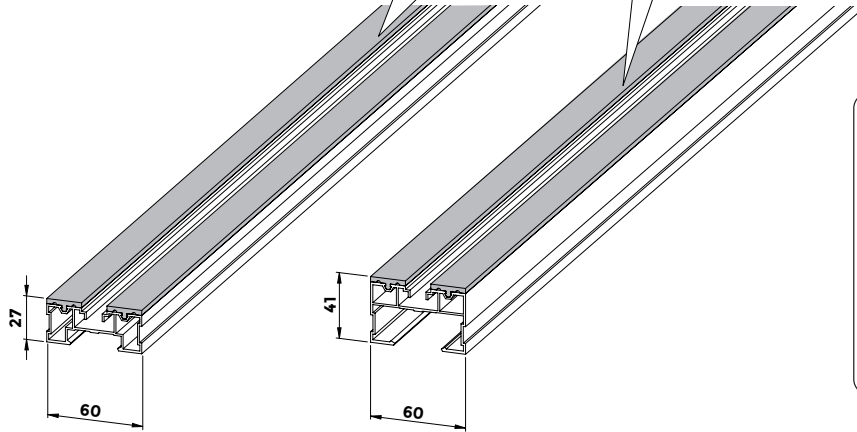

**E-BRS-27
E-BRS-27B**

**E-BRS-41
E-BRS-41B**

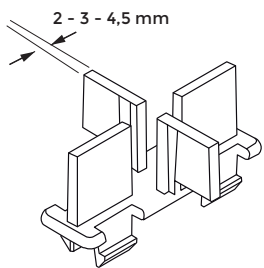
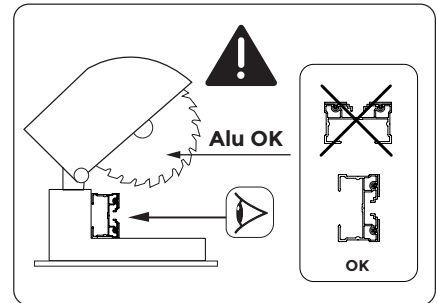

U-BRS-TABS

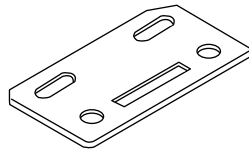

E-BRS-TOP-LINK

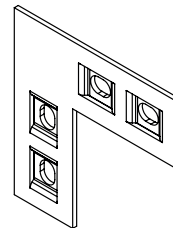

E-BRS-BRACKET

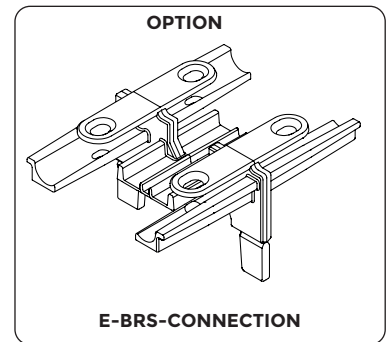

E-BRS-CONNECTION

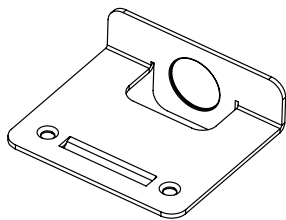

E-BRS-WALL

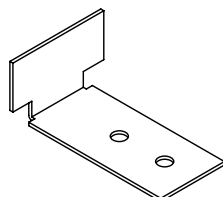

U-BRS-STOP

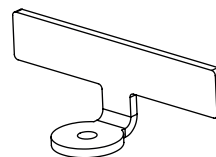

E-BRS-STOP-ROUND

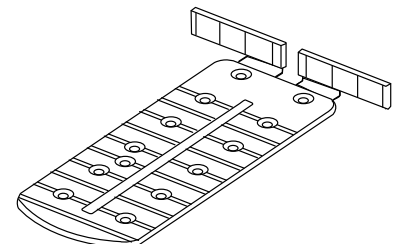

U-WALL-PP

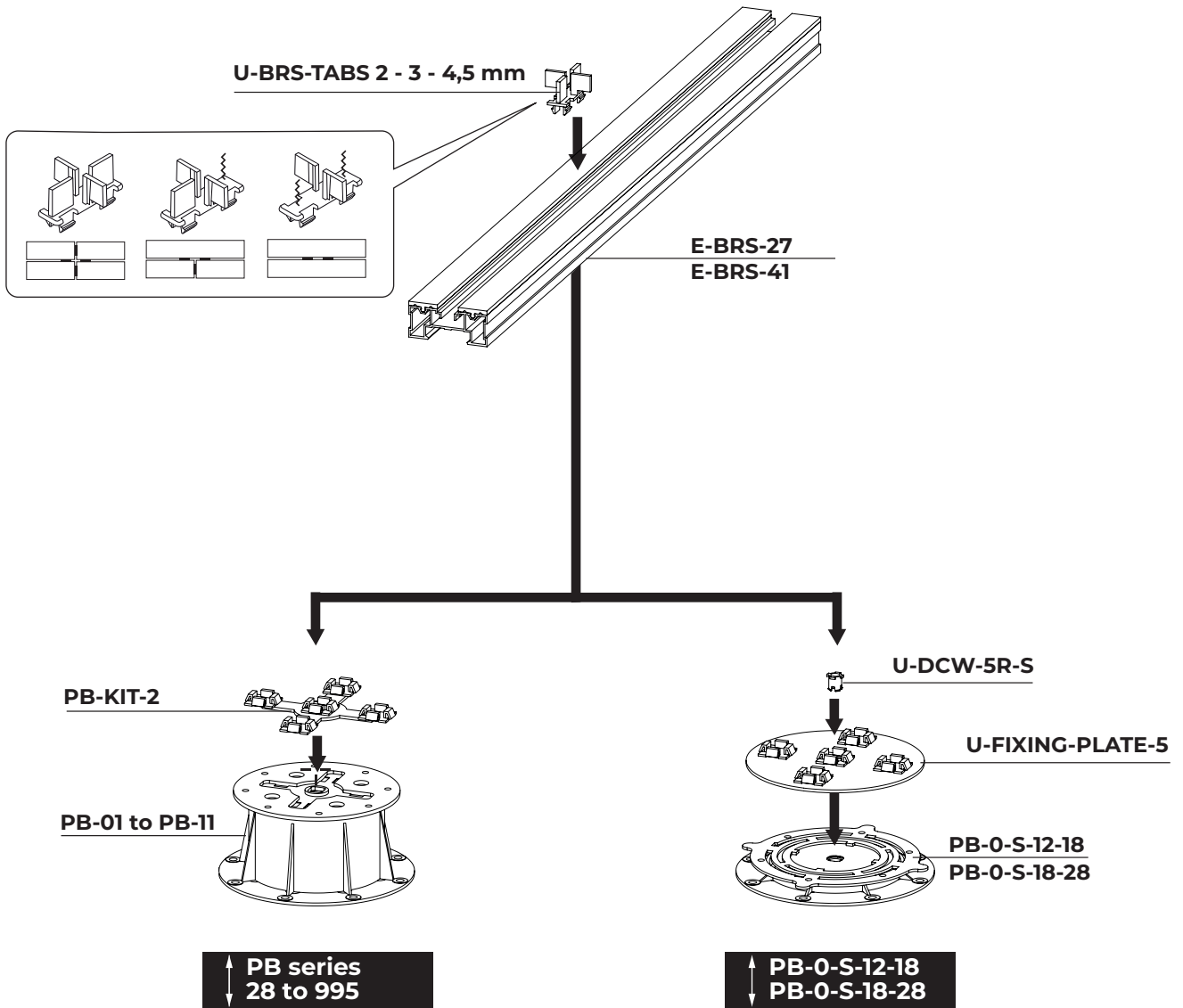

E-BRS-27

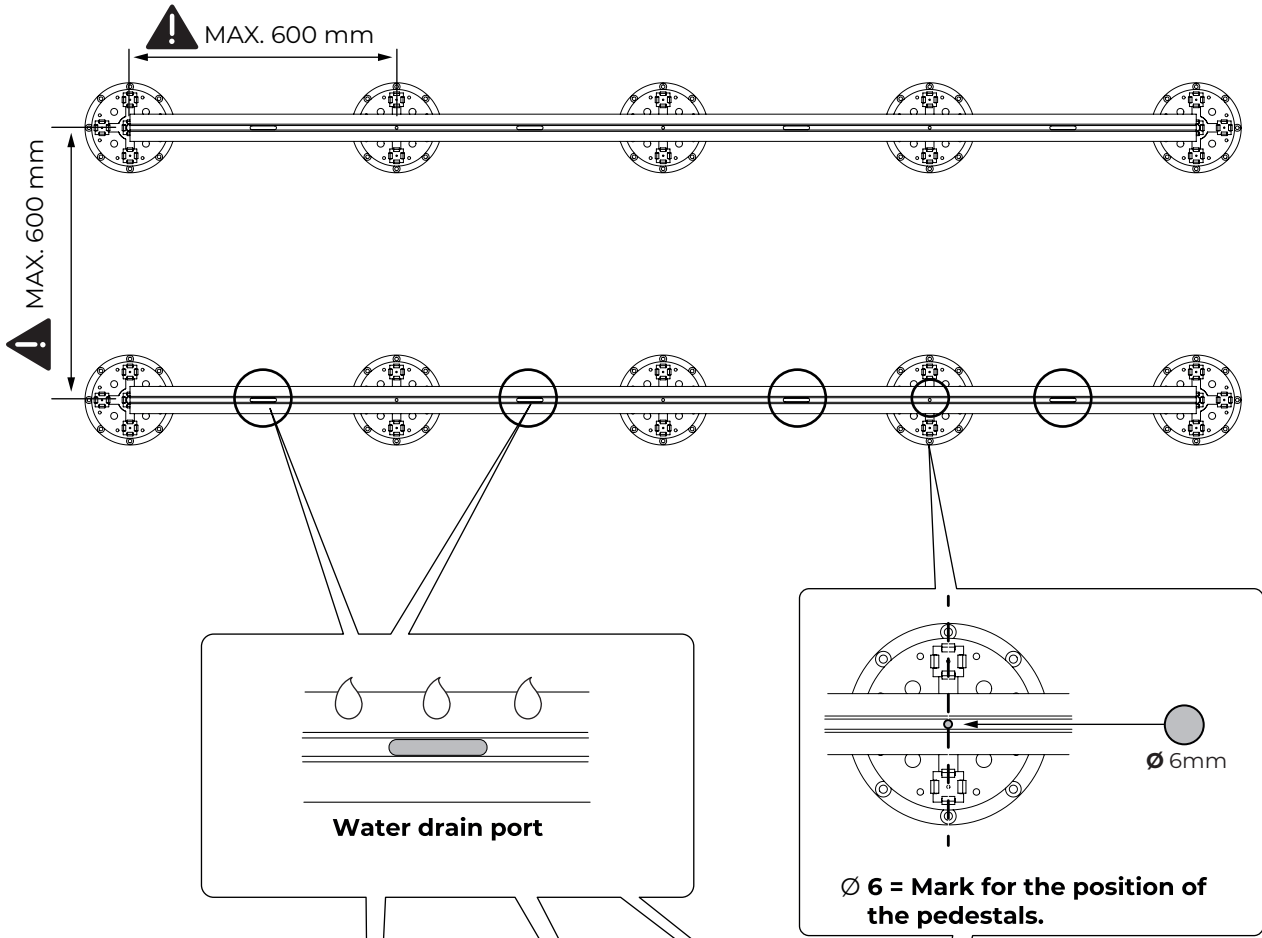

E-BRS-41

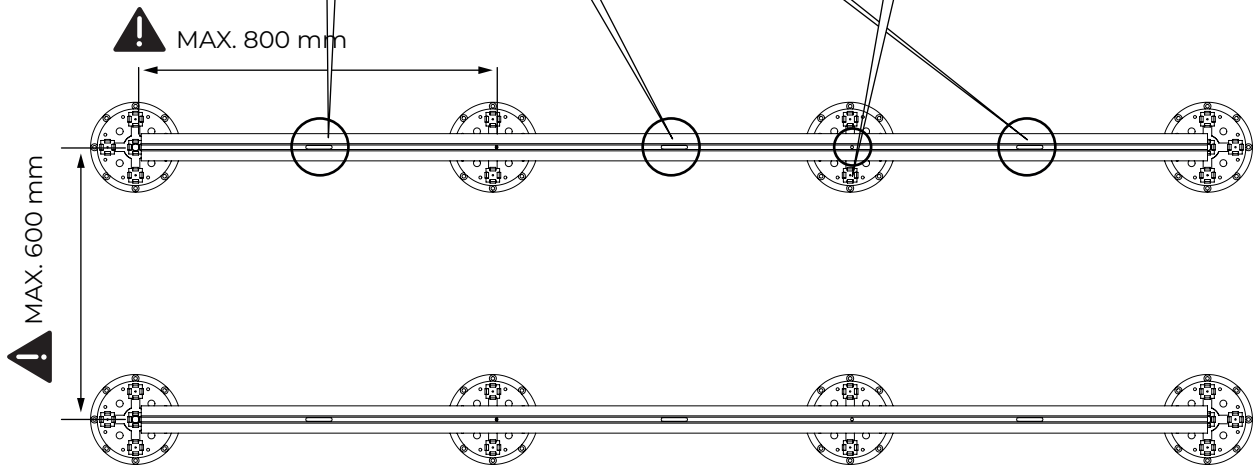

PB-KIT-2

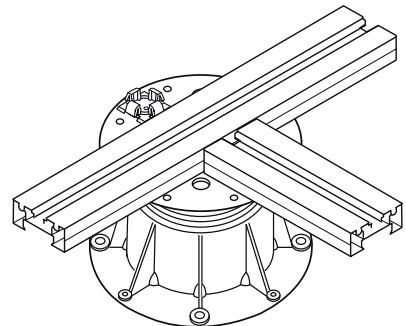
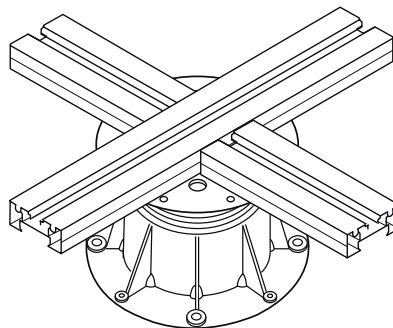
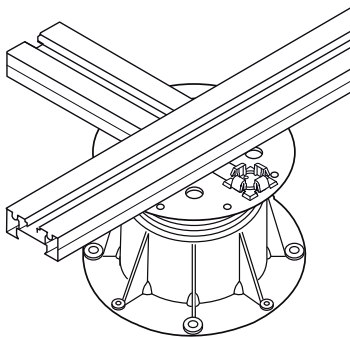
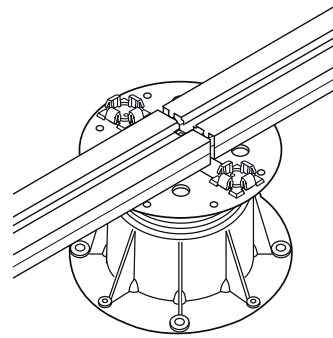
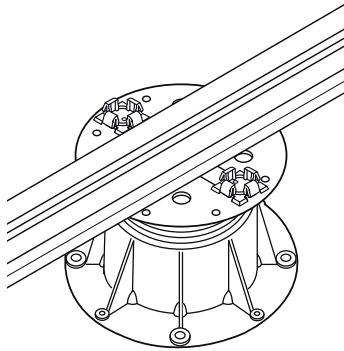
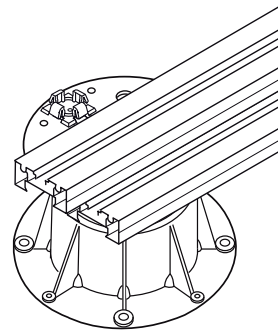
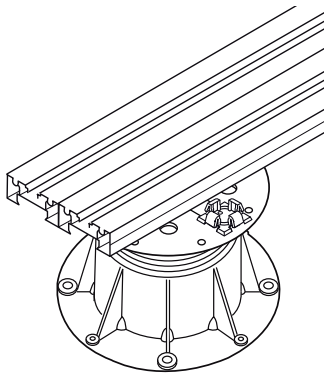
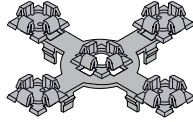

1

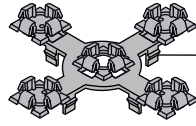

PB-KIT-2

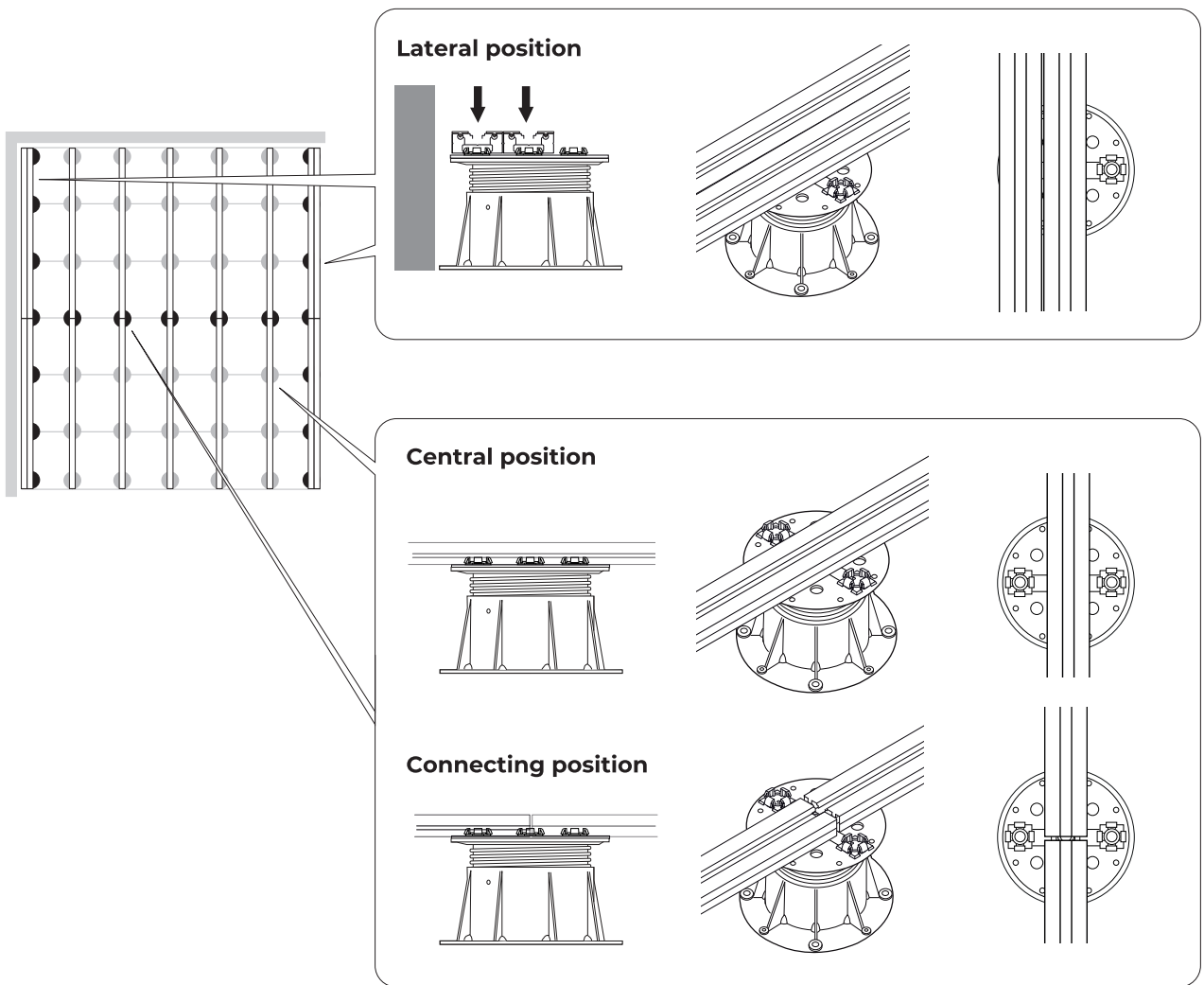
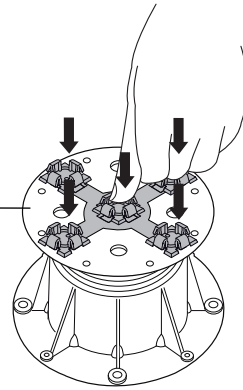

2

Exemple : Terrasse 4,80 m x 3,60 m

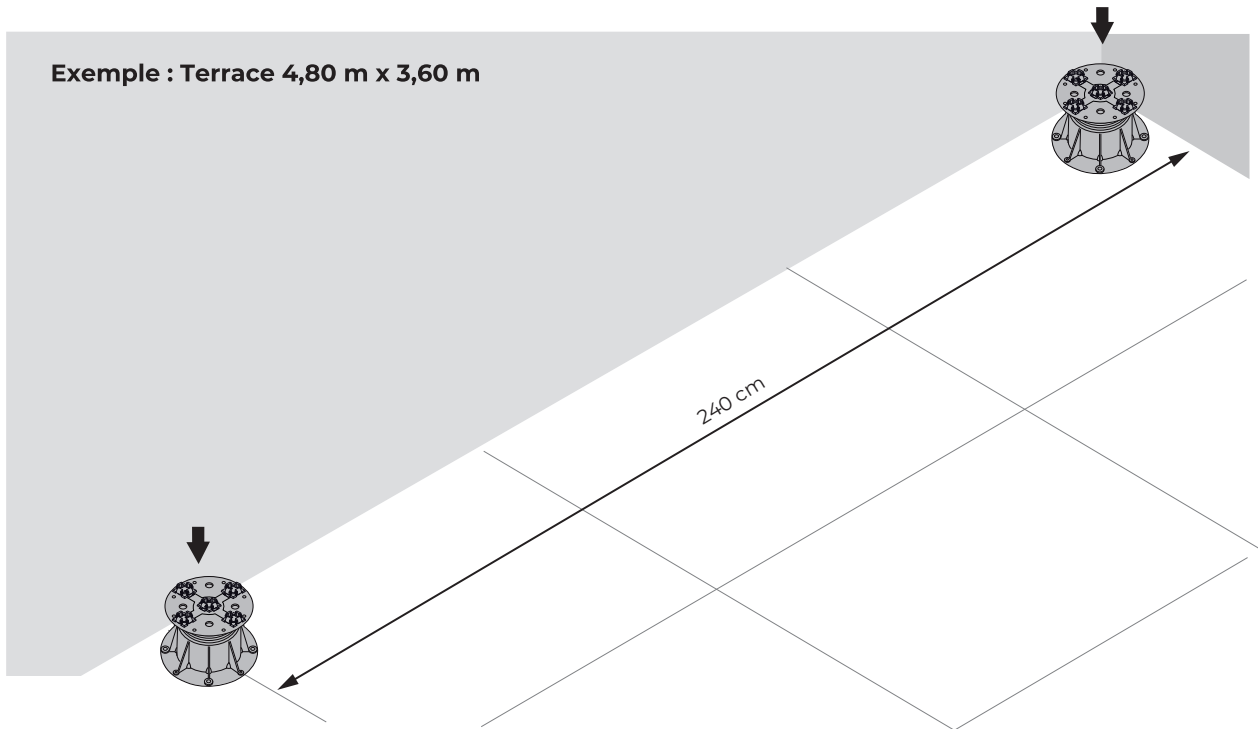

3

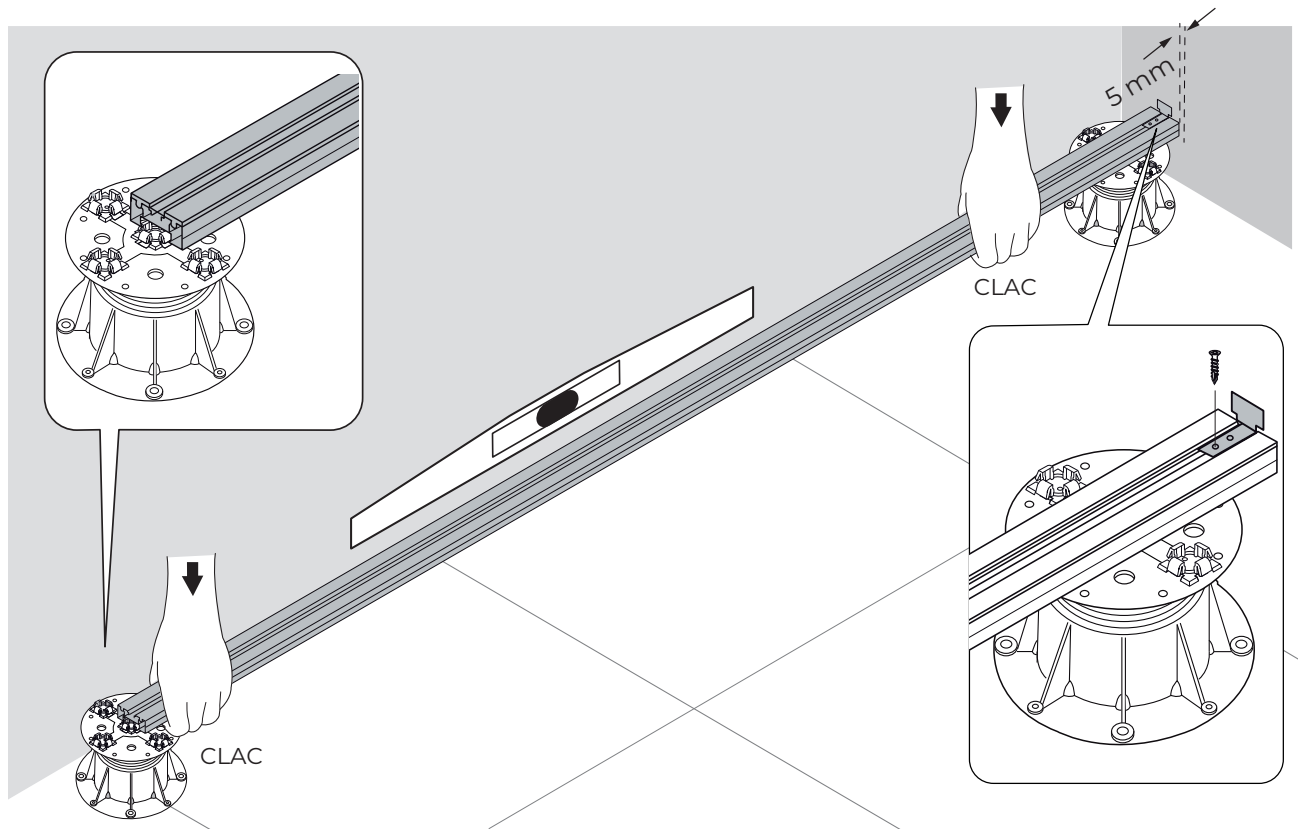

4

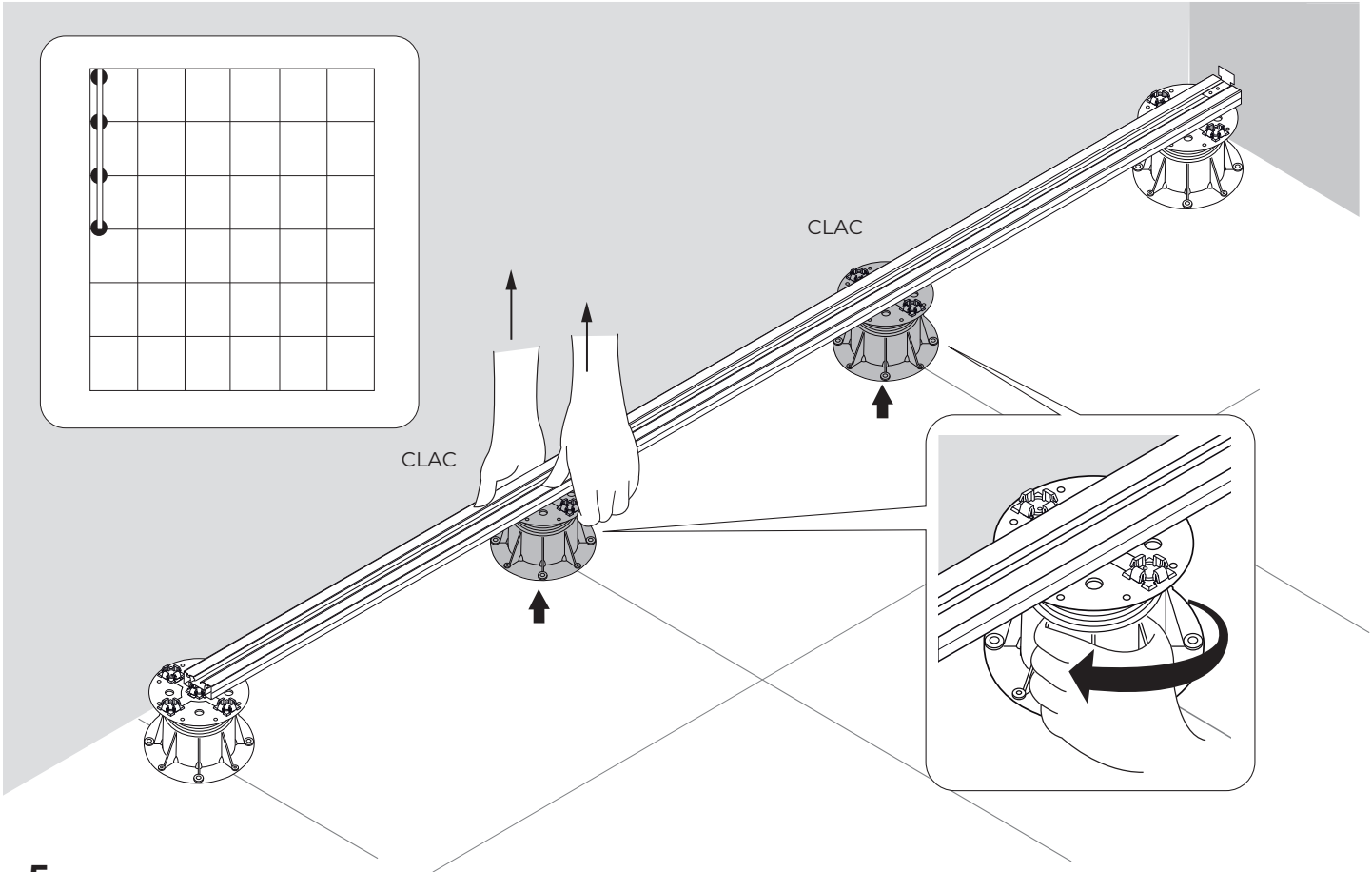

5

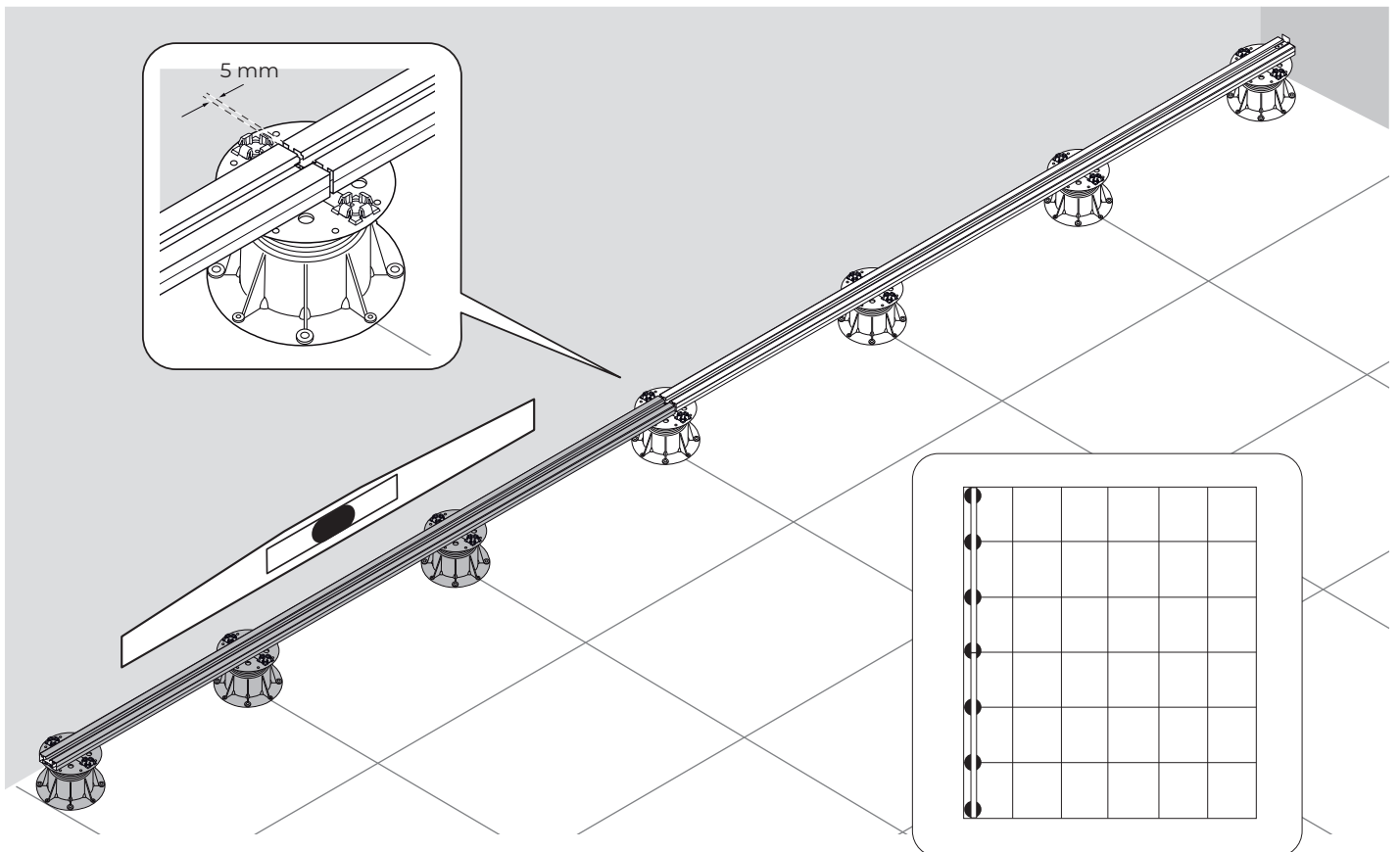

6 Double rail in lateral position

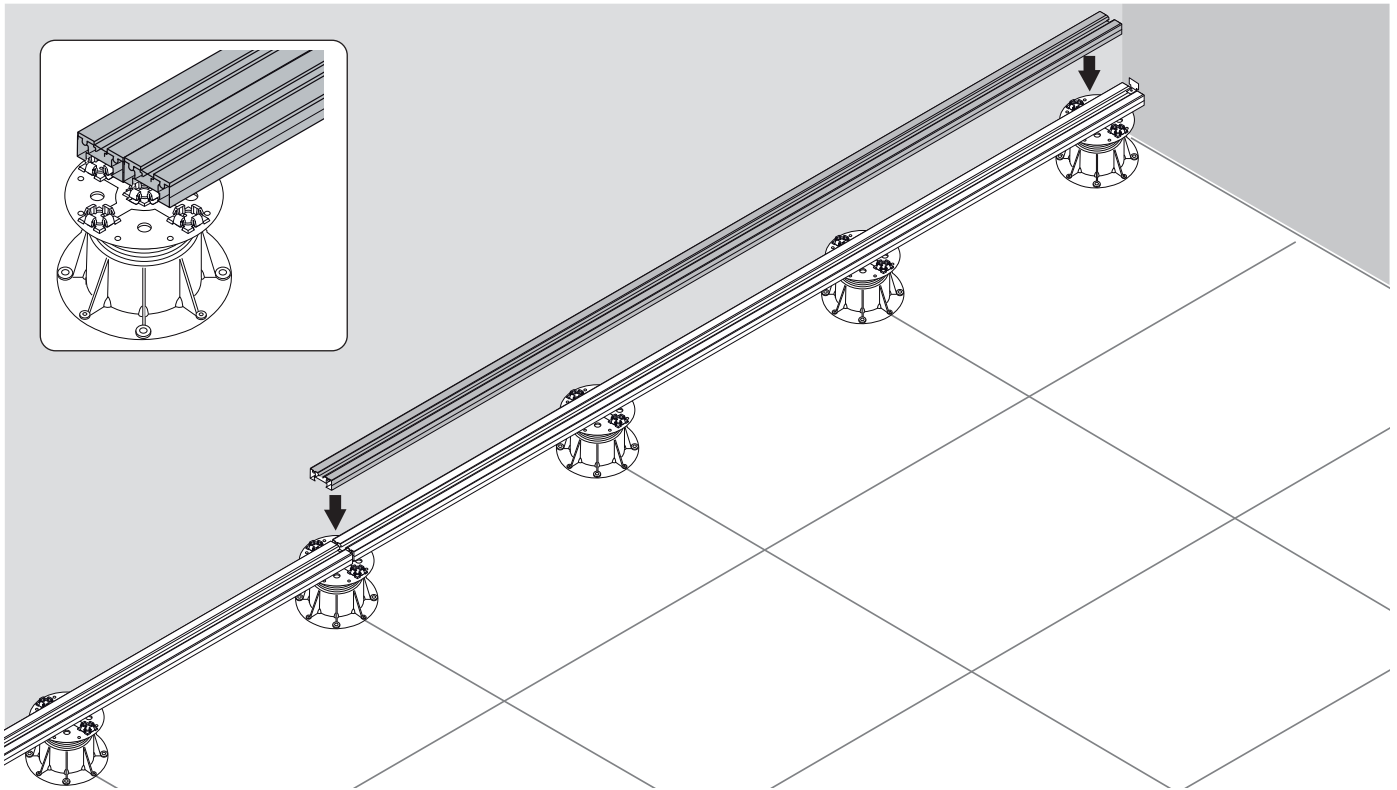

7

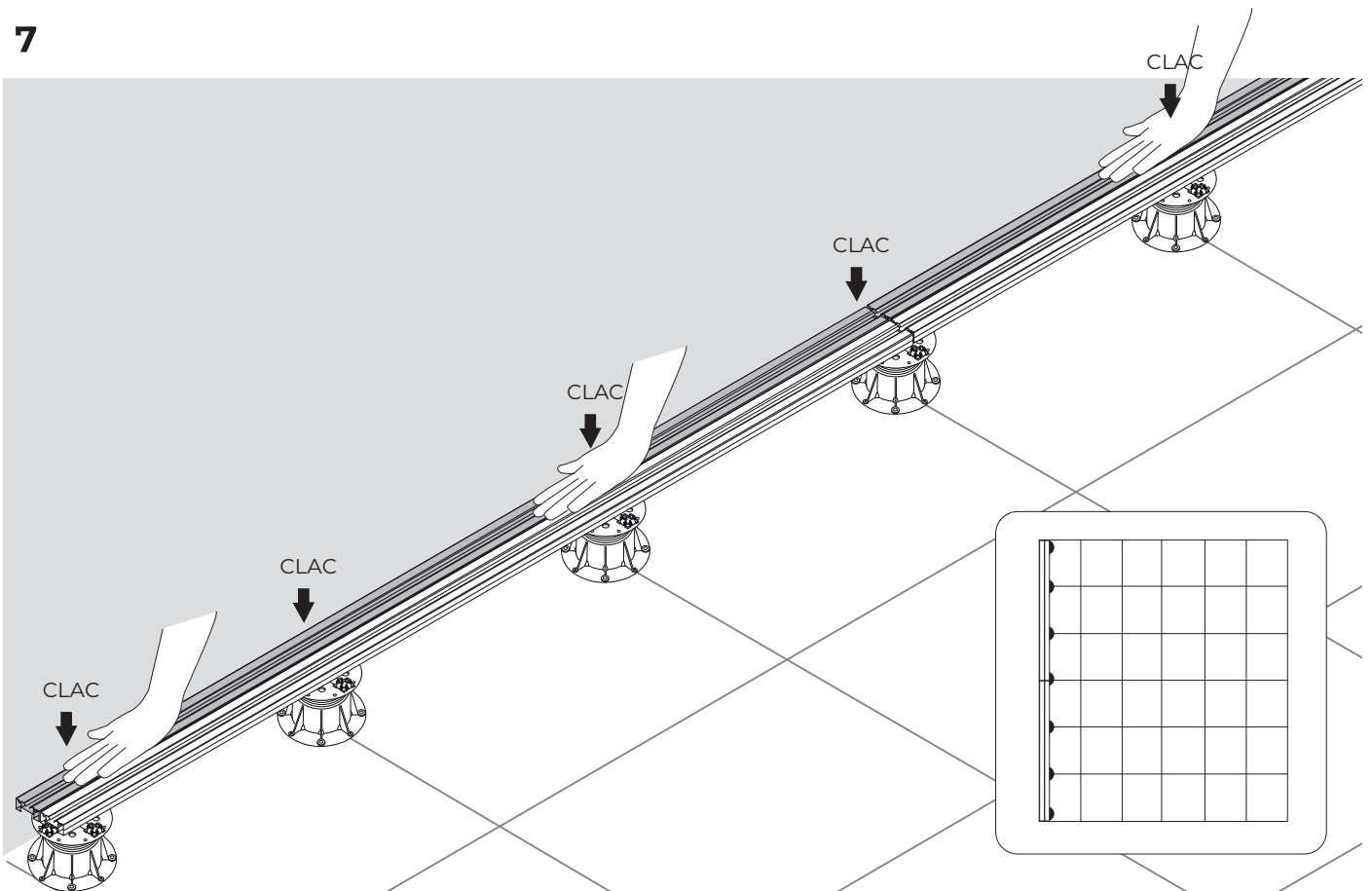

8

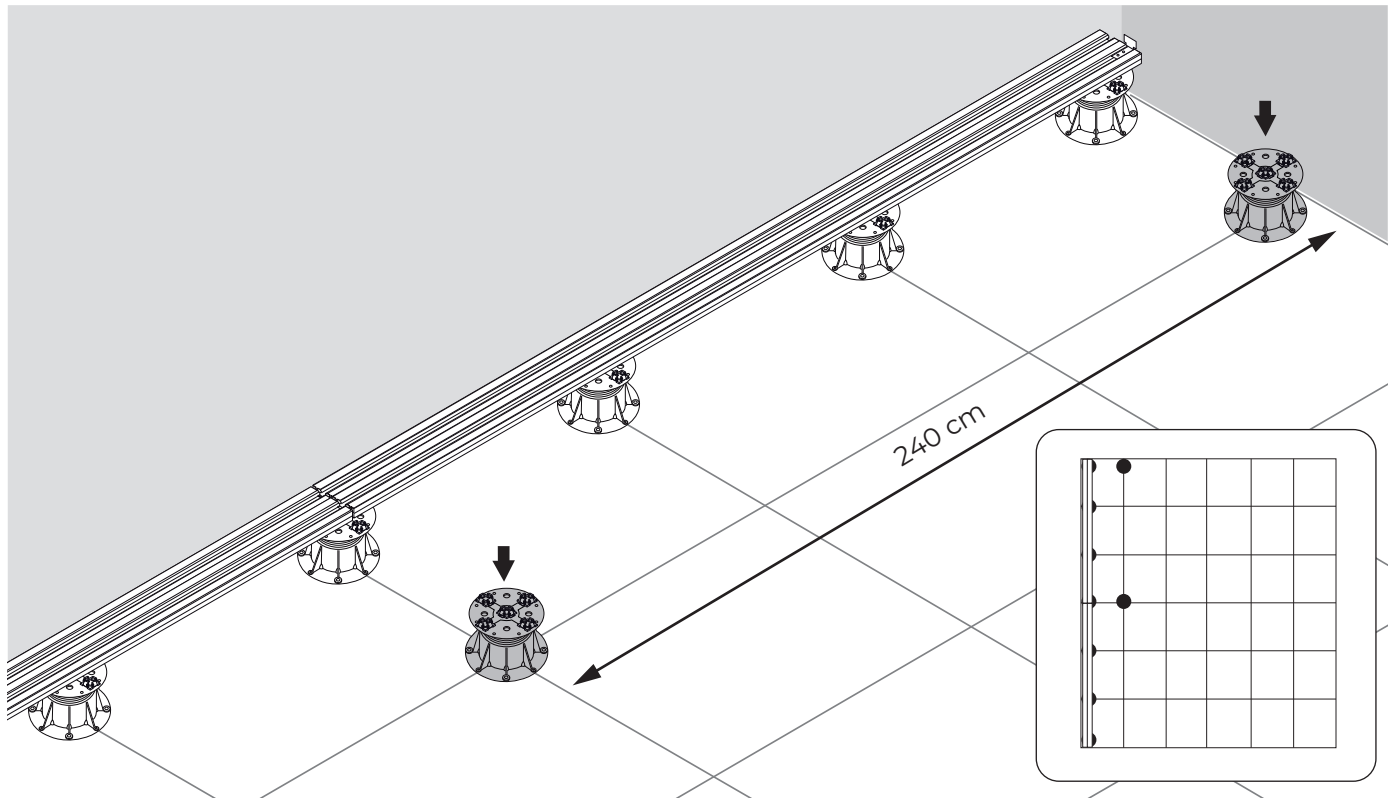

9

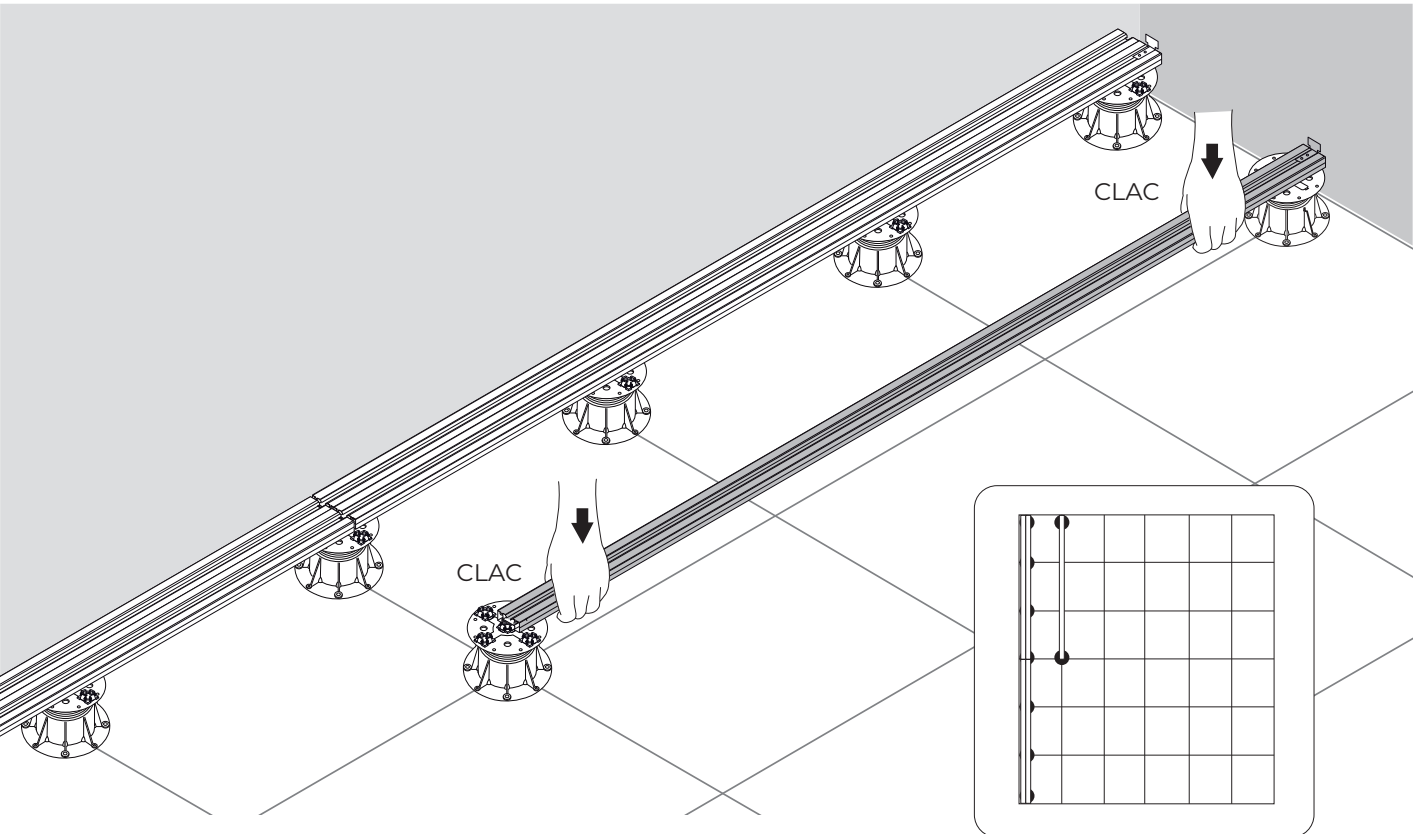

10

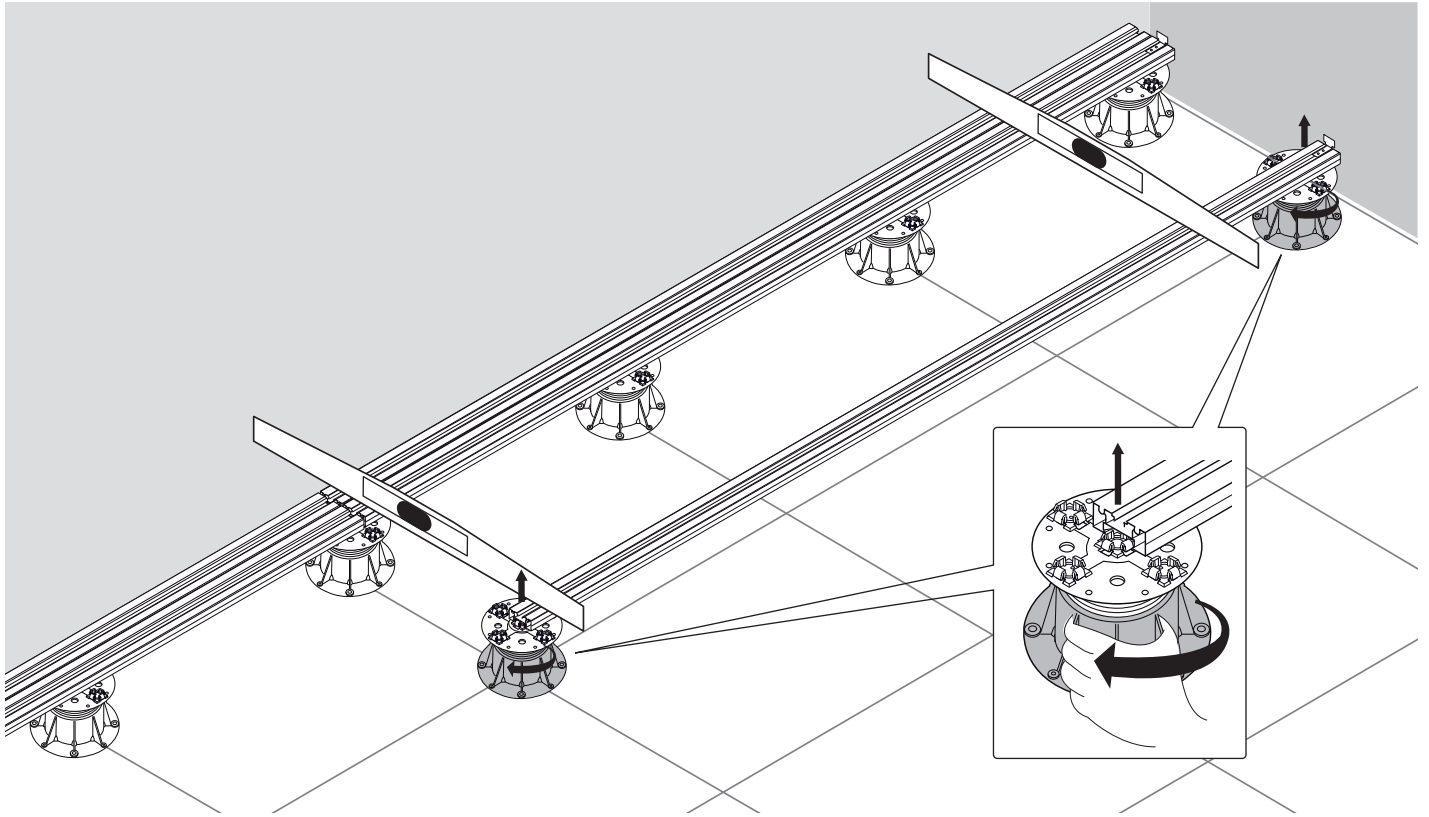

11

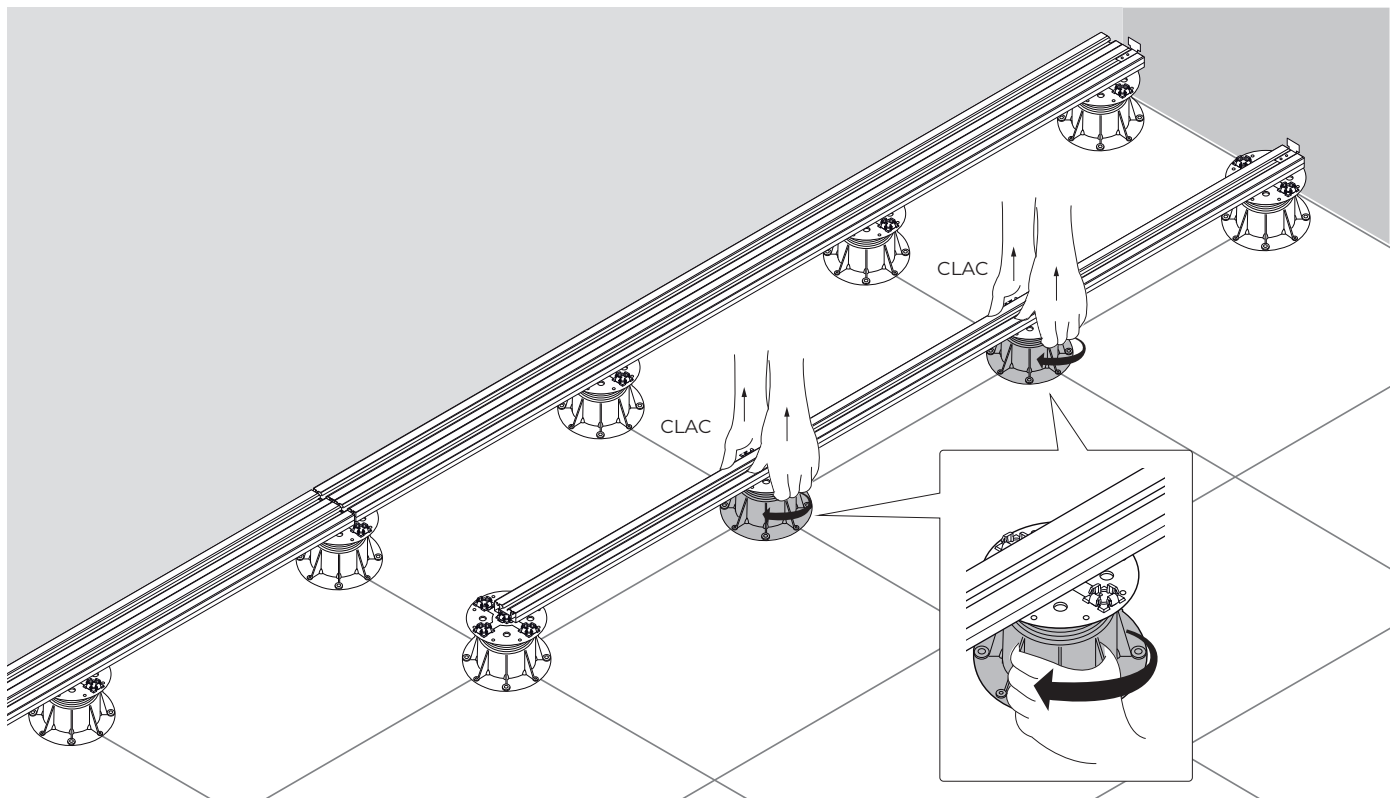

12

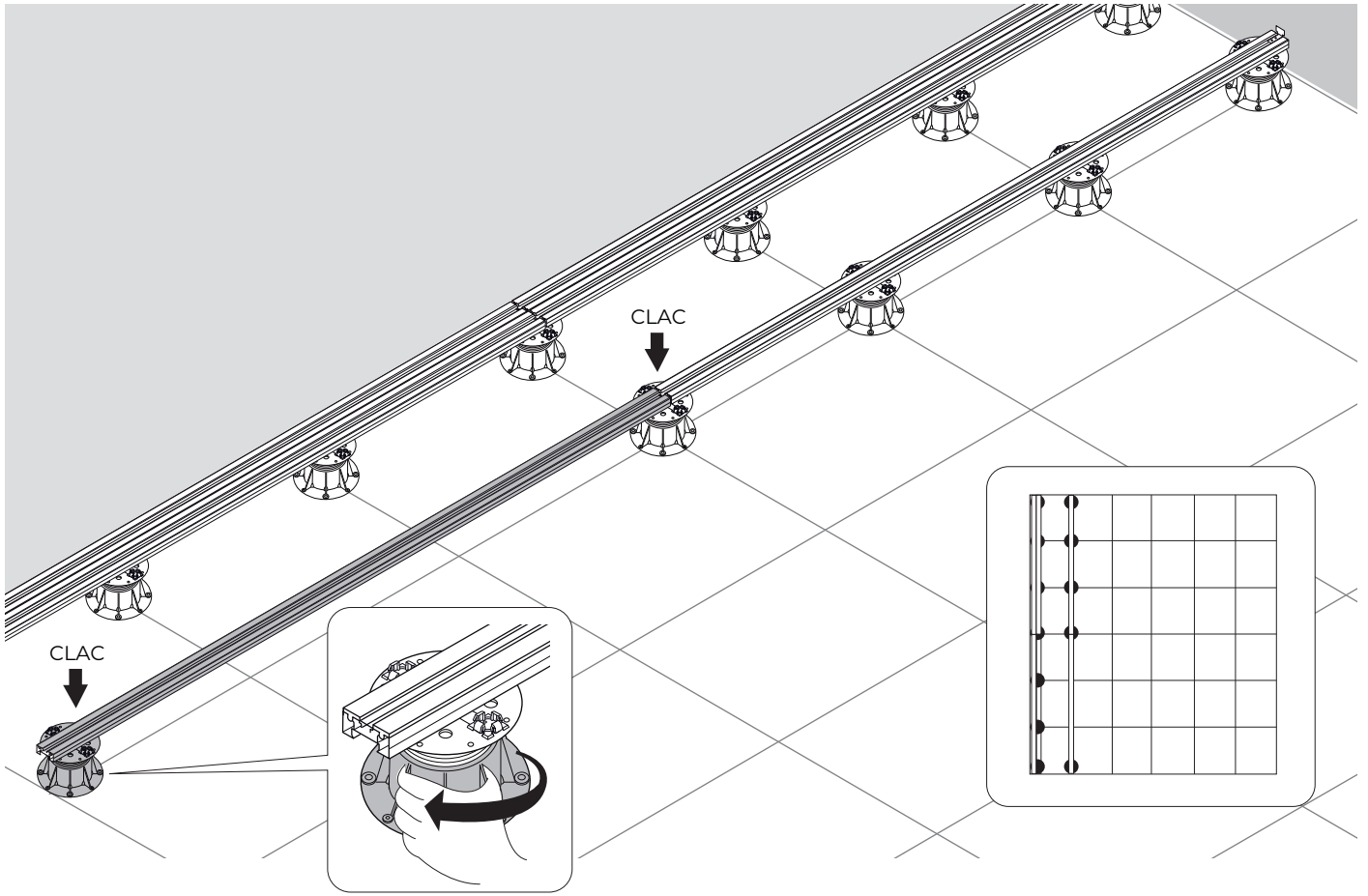

13

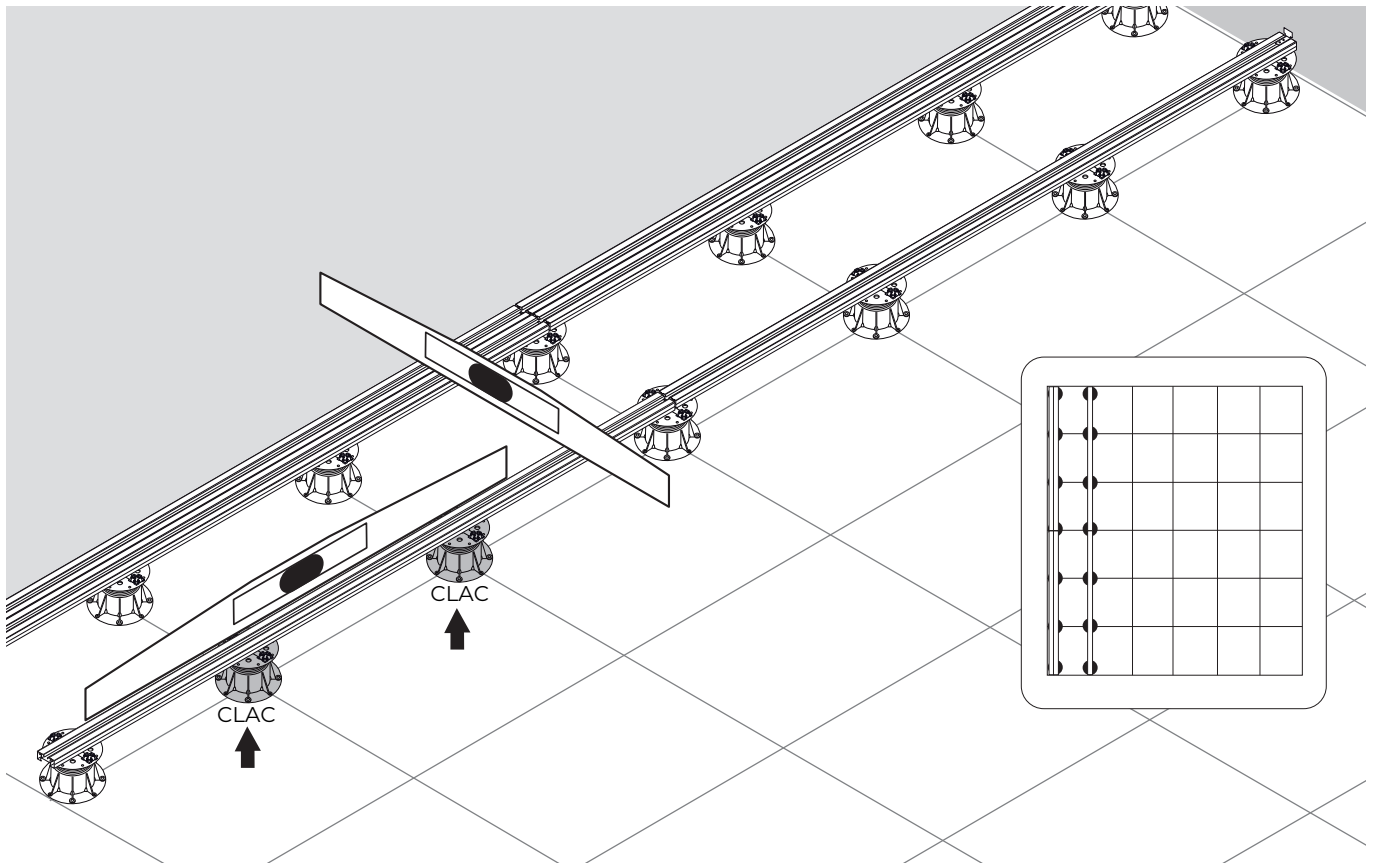

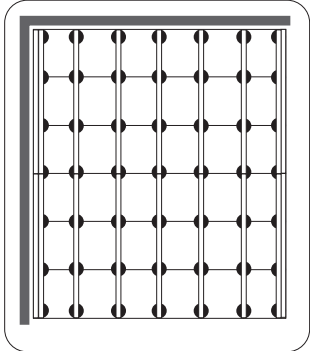
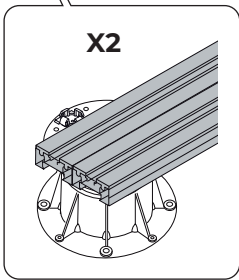
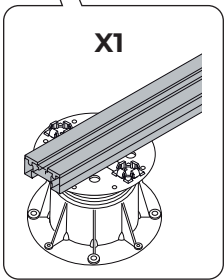
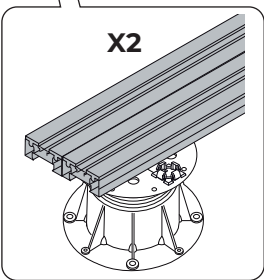
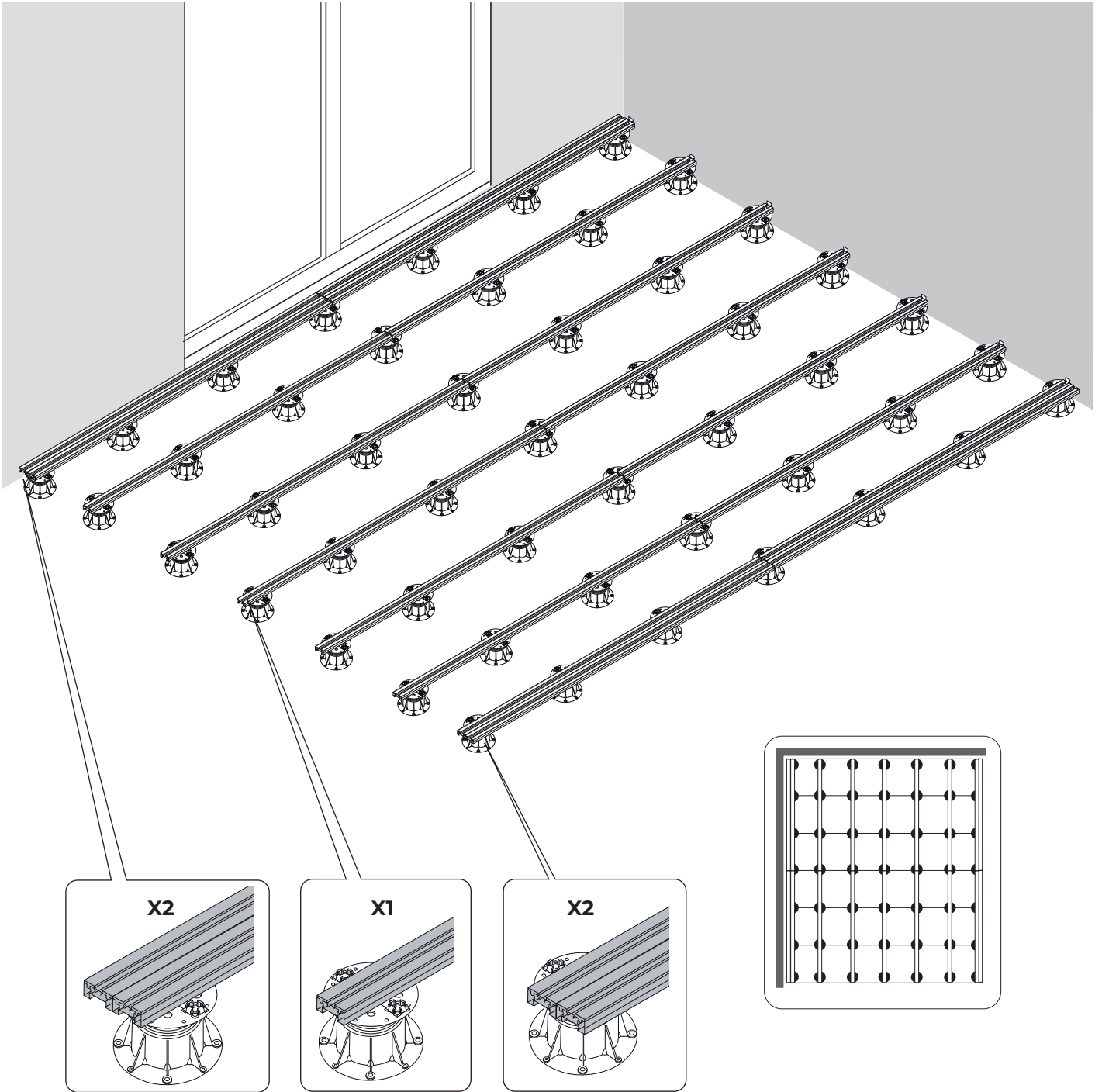

15

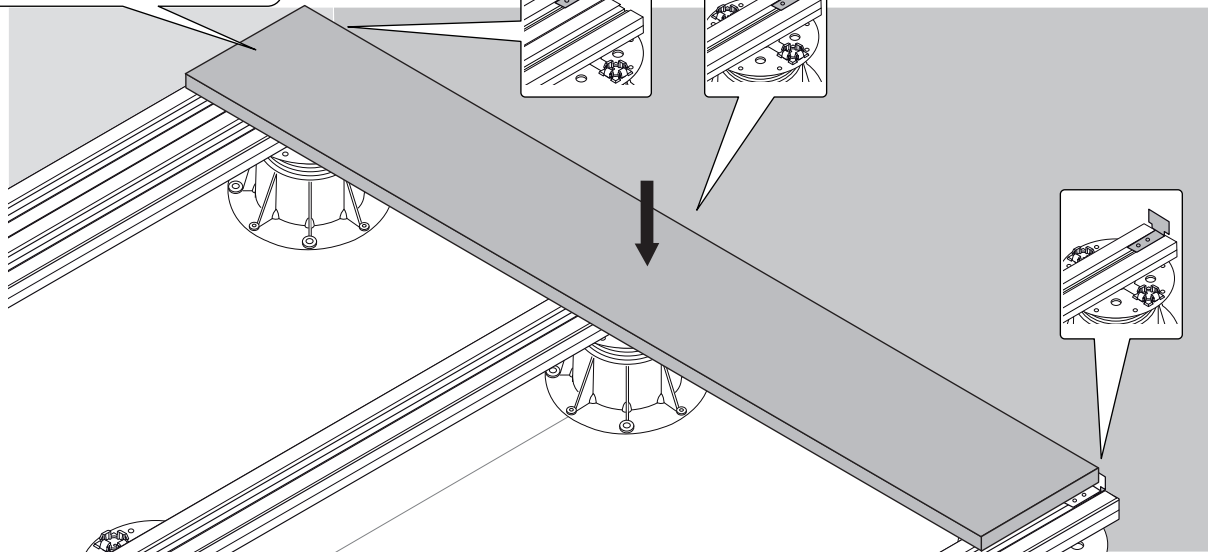
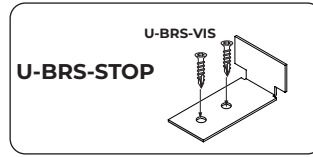
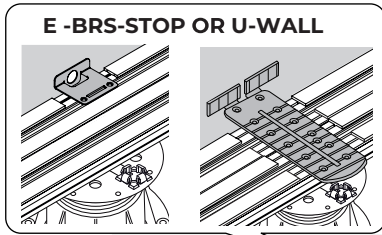

16

U-BRS-TABS

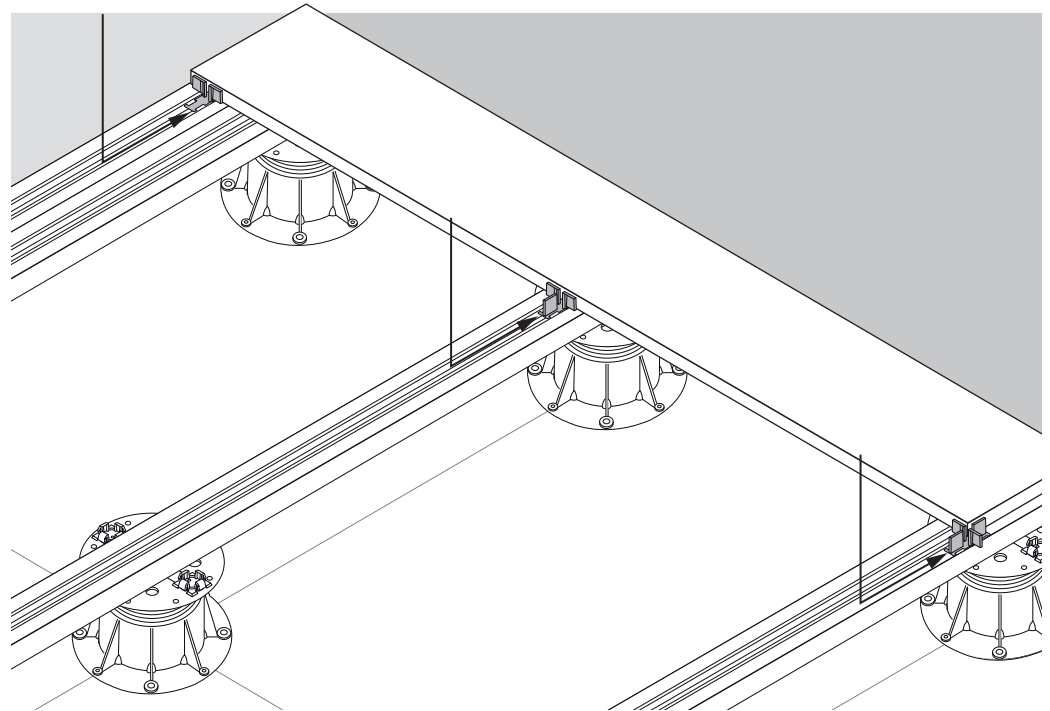
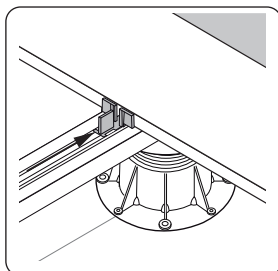
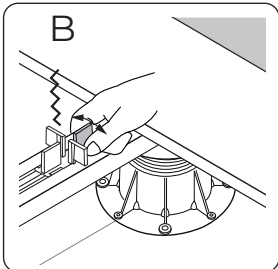
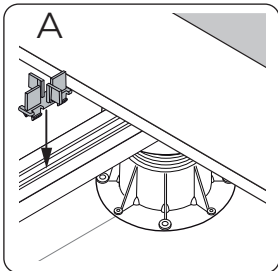
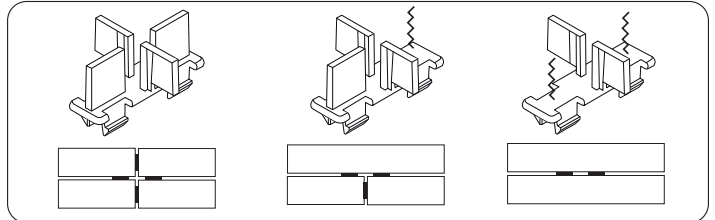
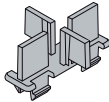

17

E -BRS-STOP OU U-WALL

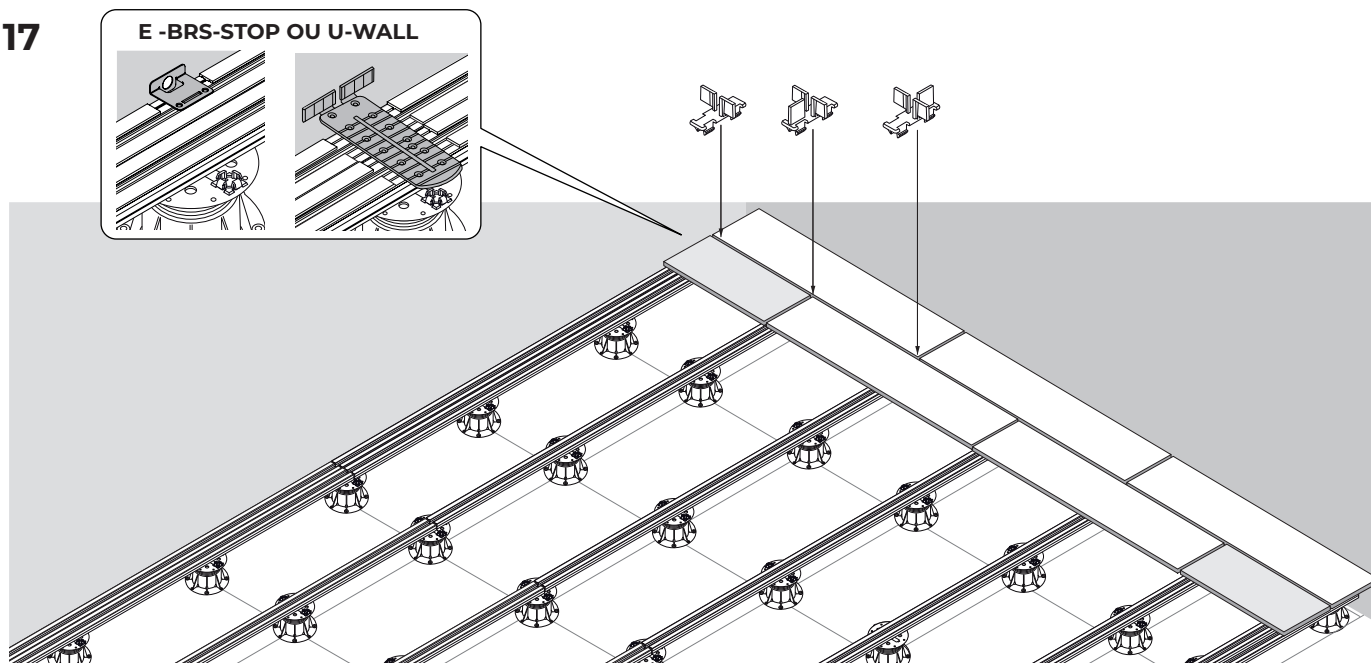

18

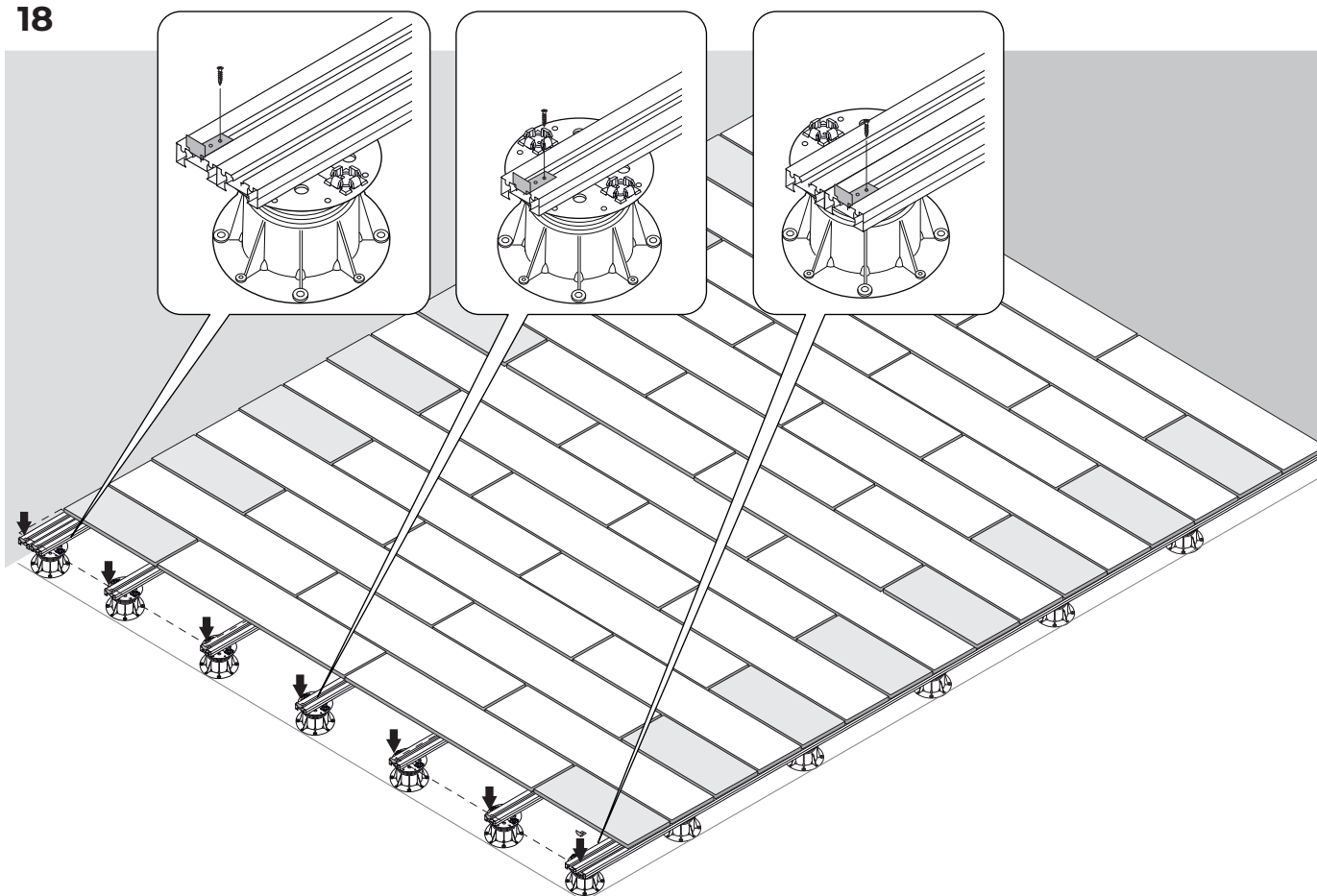

19

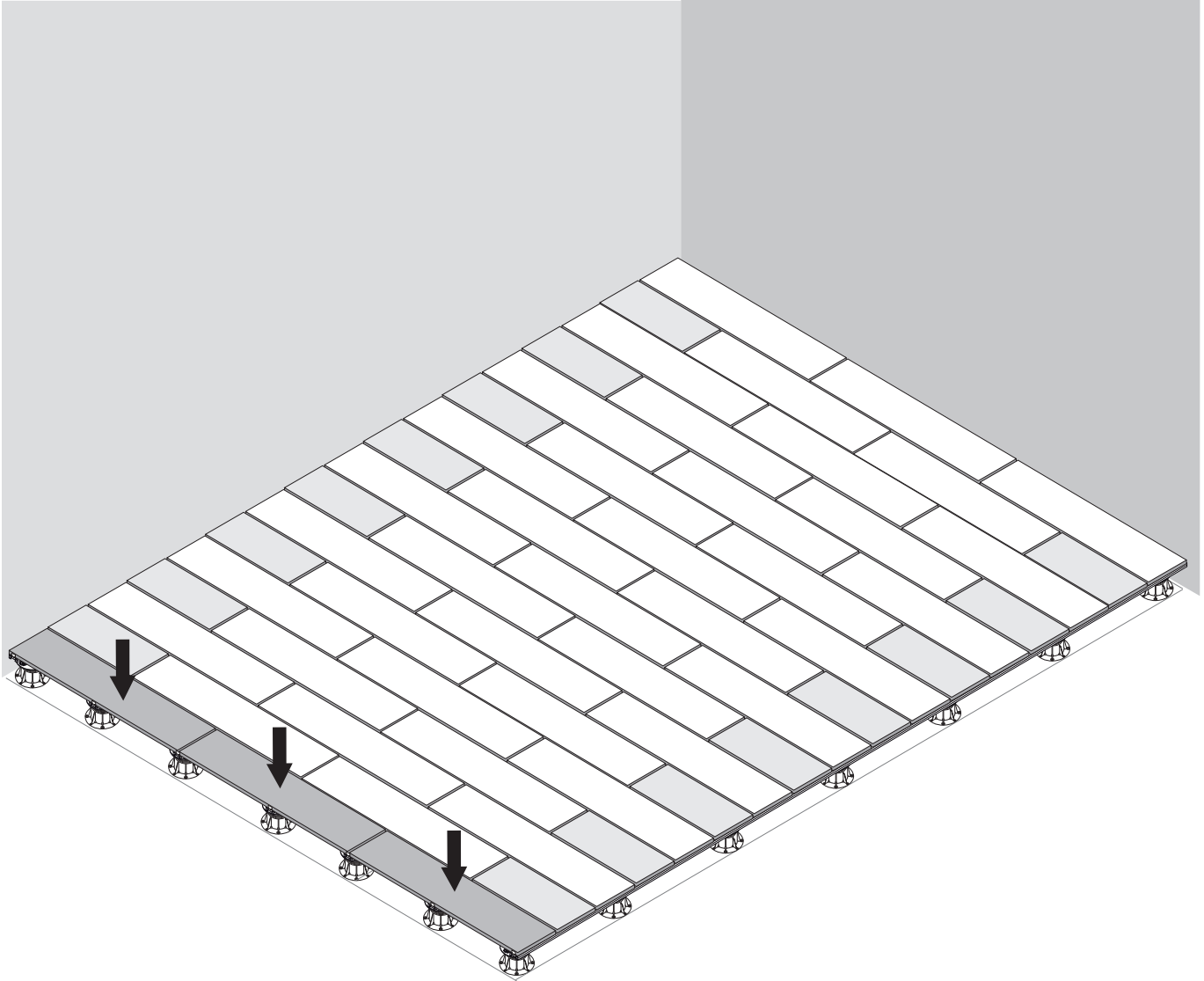

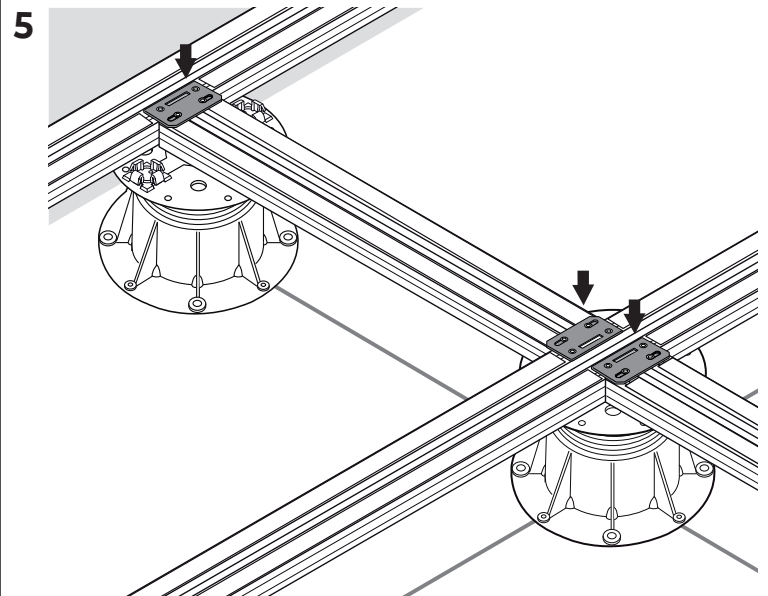
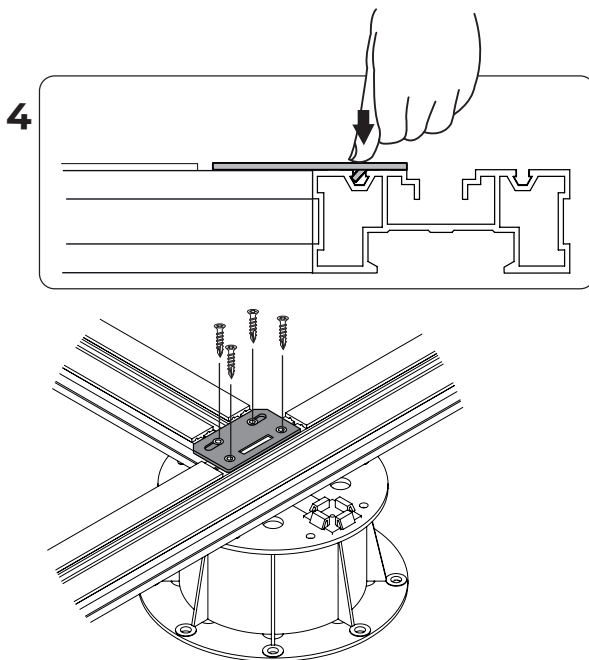
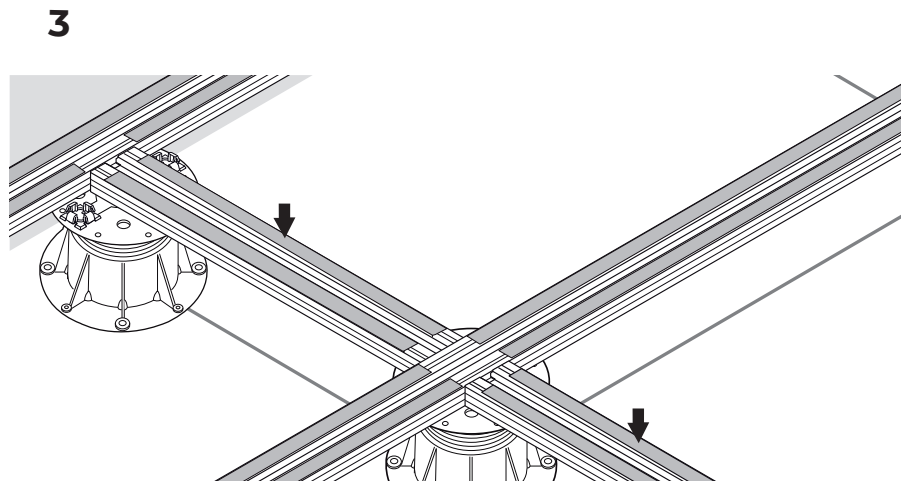
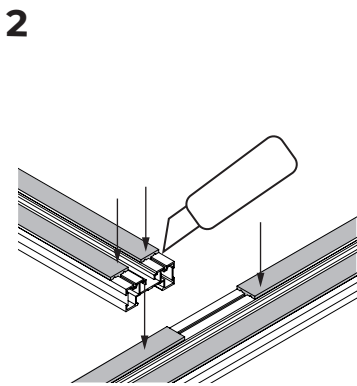
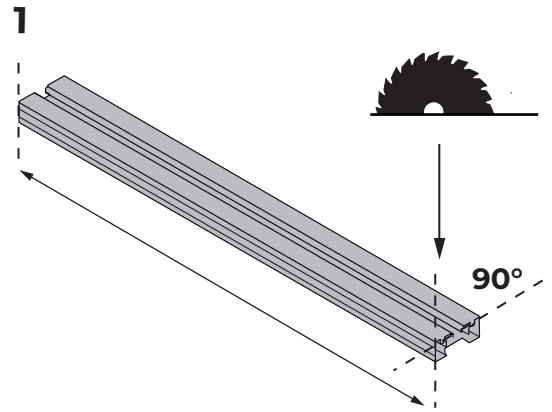
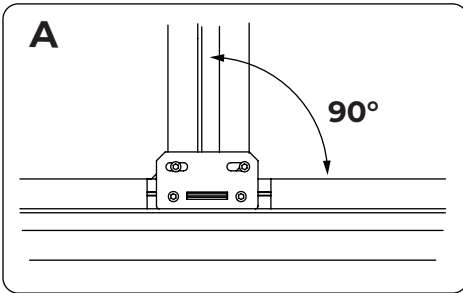
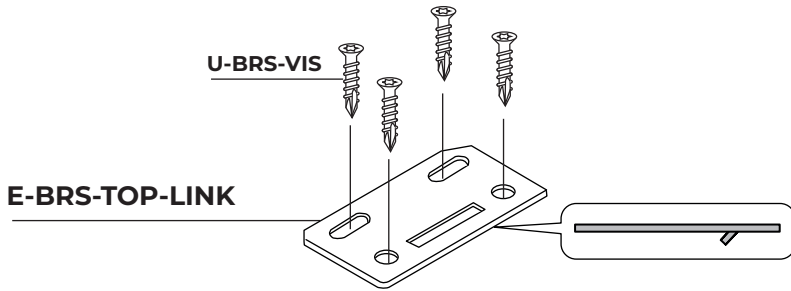

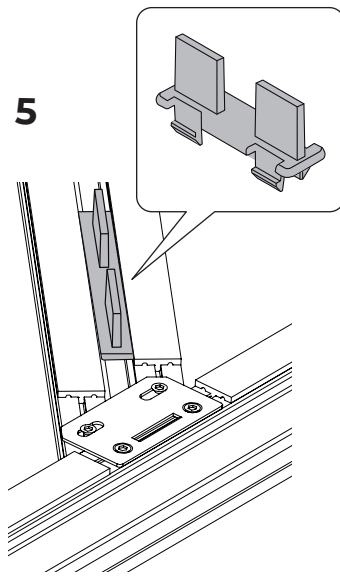
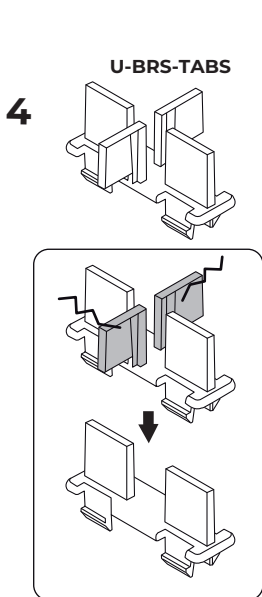
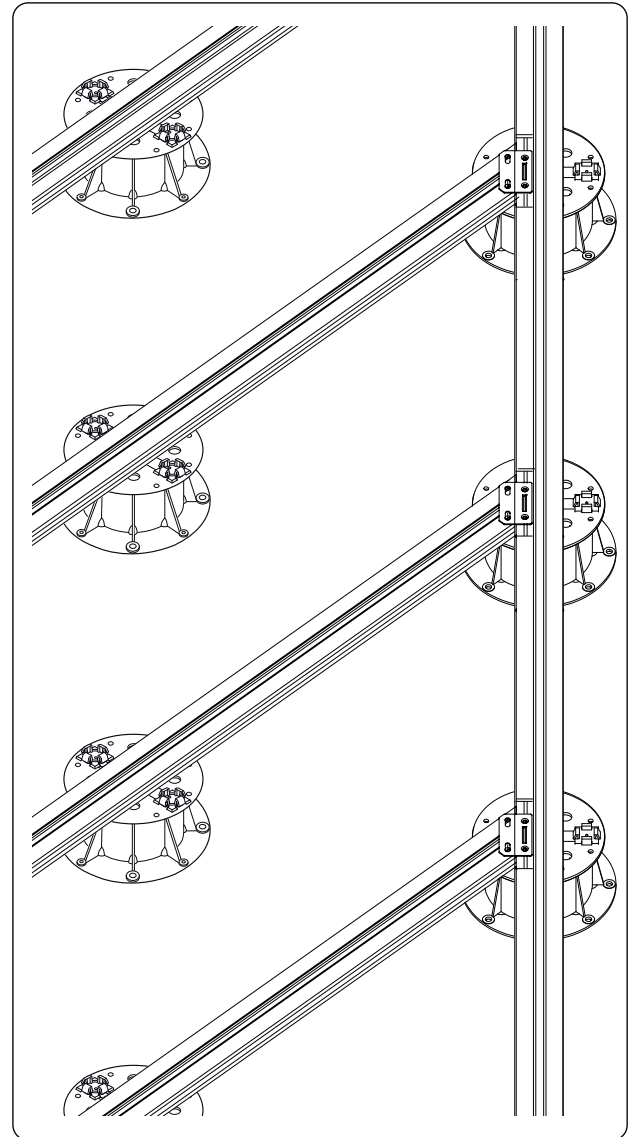
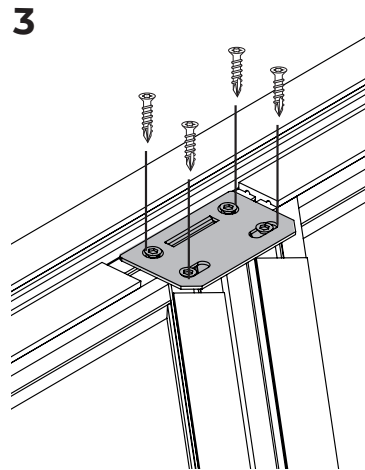
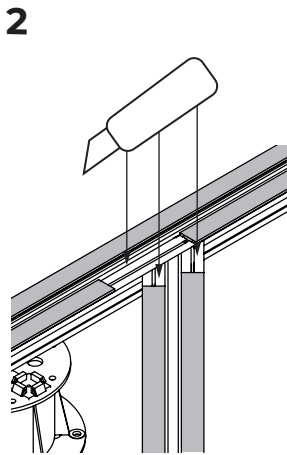
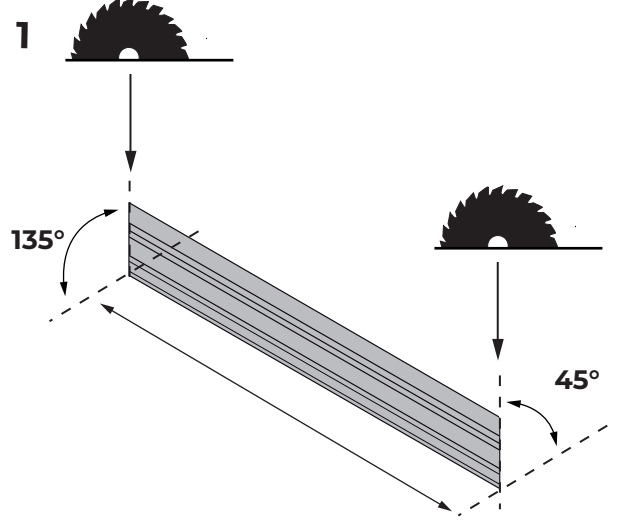
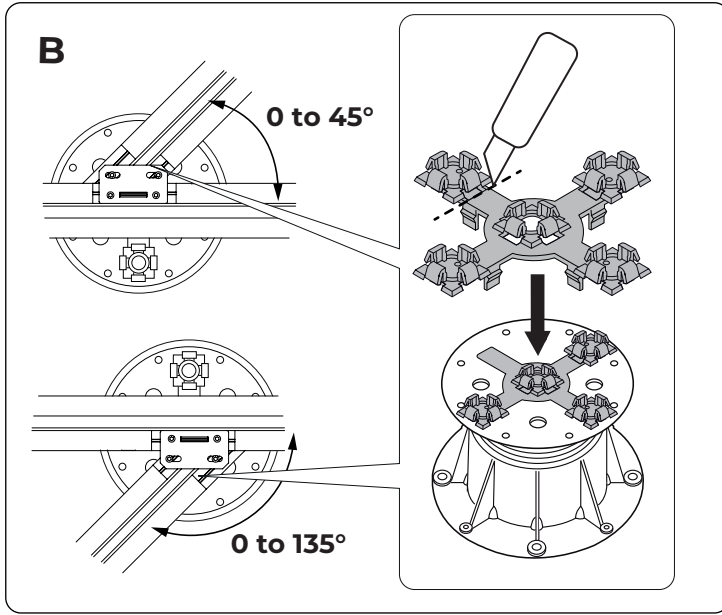

Rail locking with E-BRS-TOP-LINK

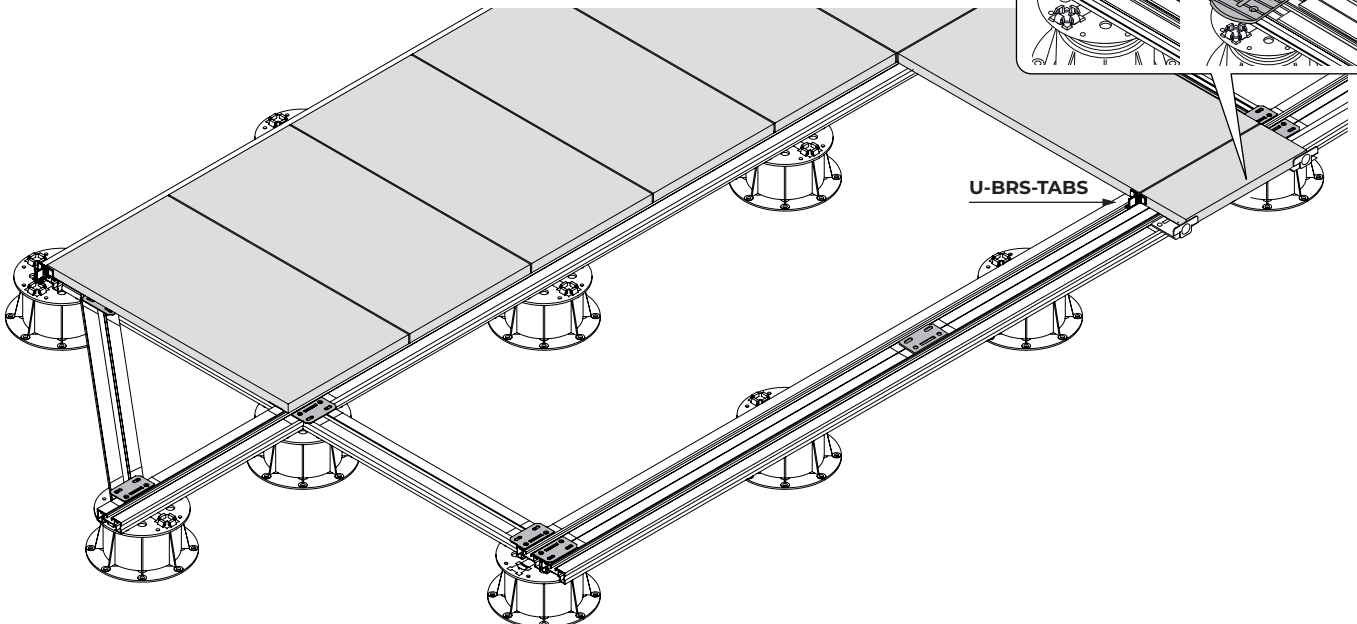
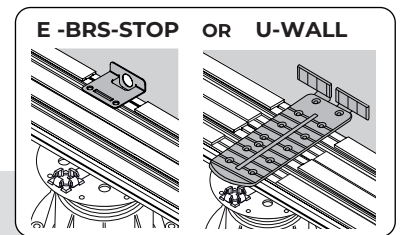
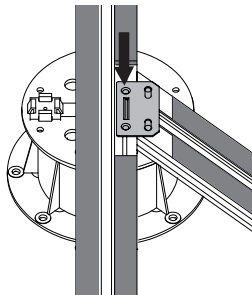
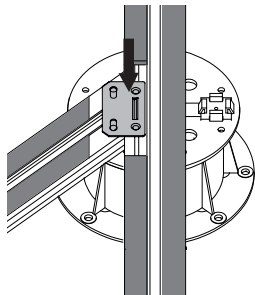
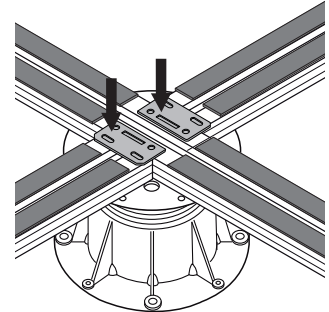
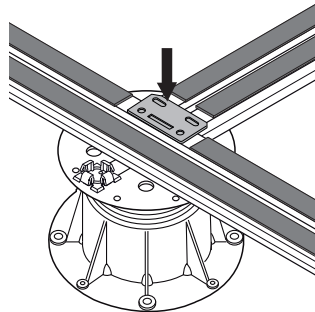
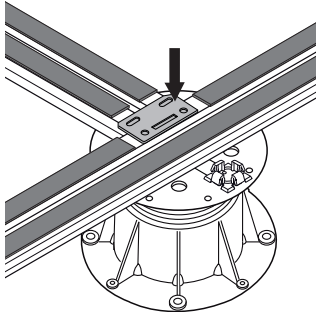
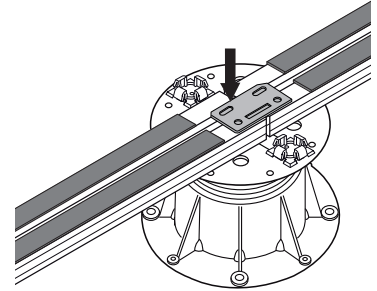
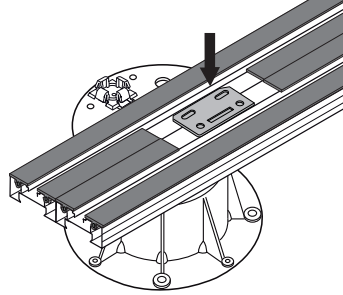
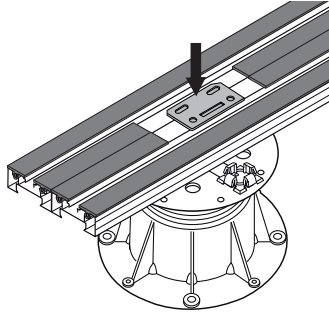
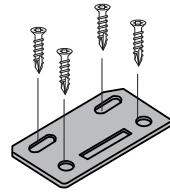

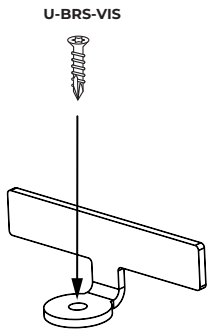

E-BRS-STOP-ROUND

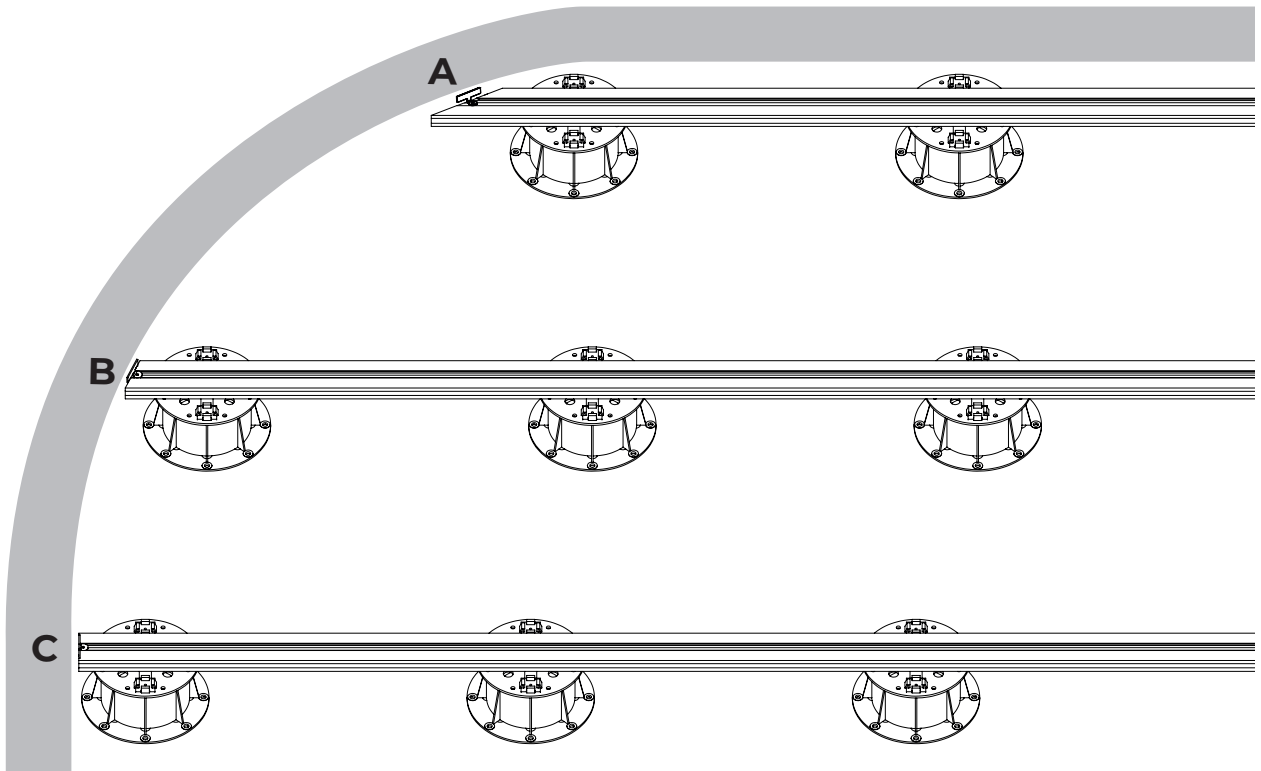
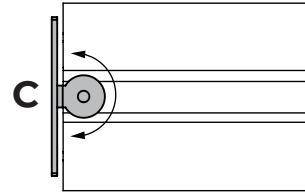
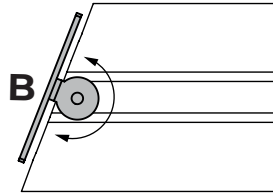
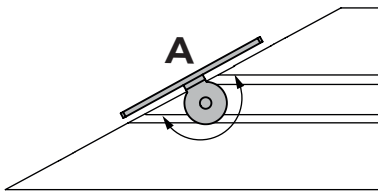
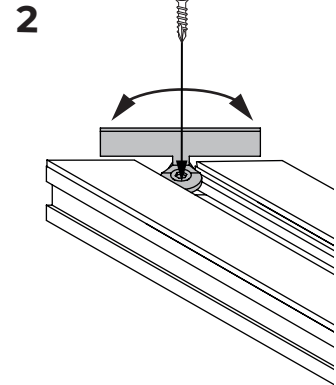
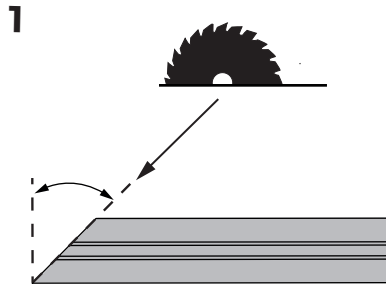

E-BRS-WALL

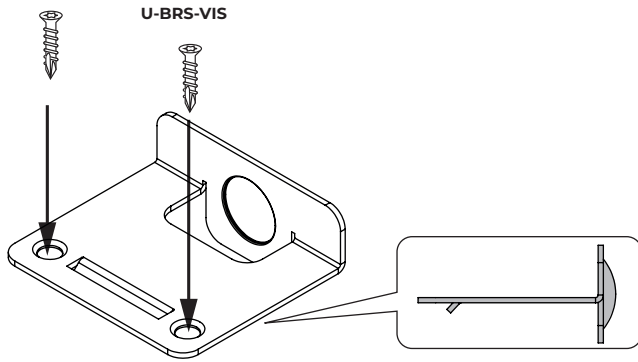

1

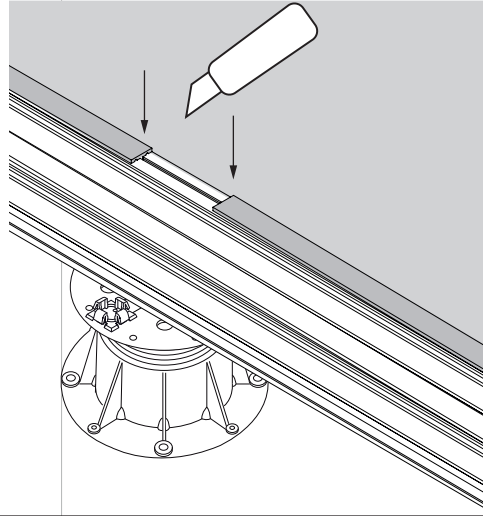

2

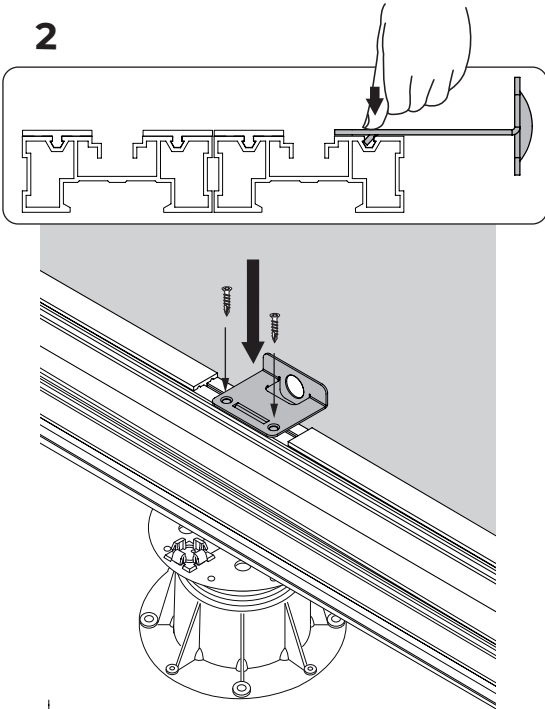

3

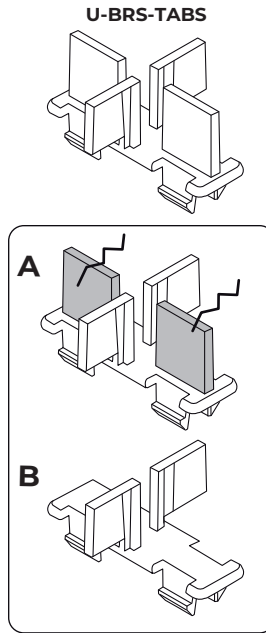

4

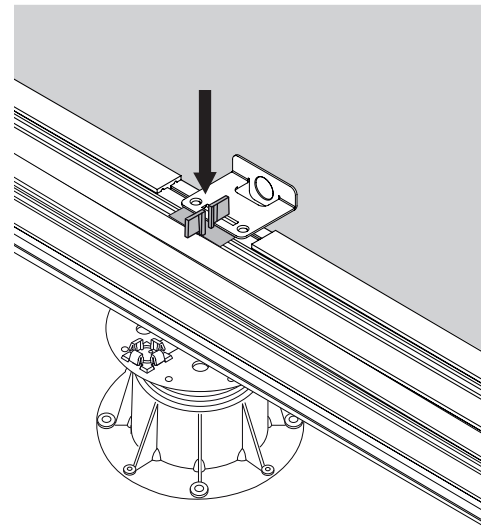

5

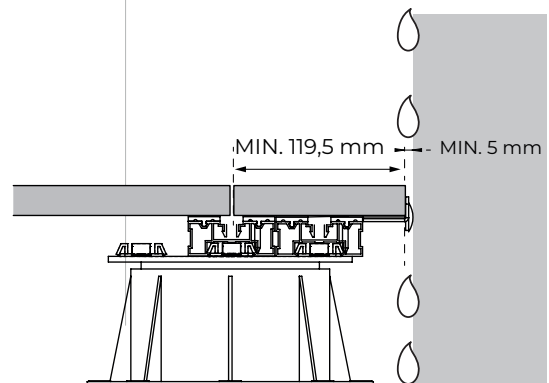
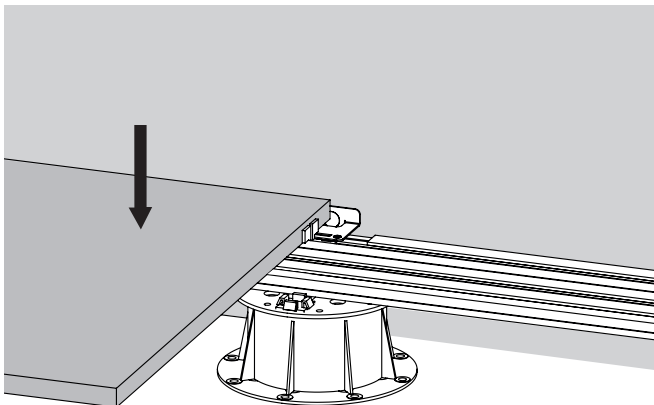

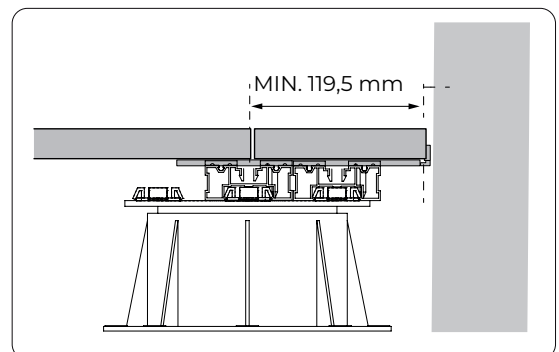
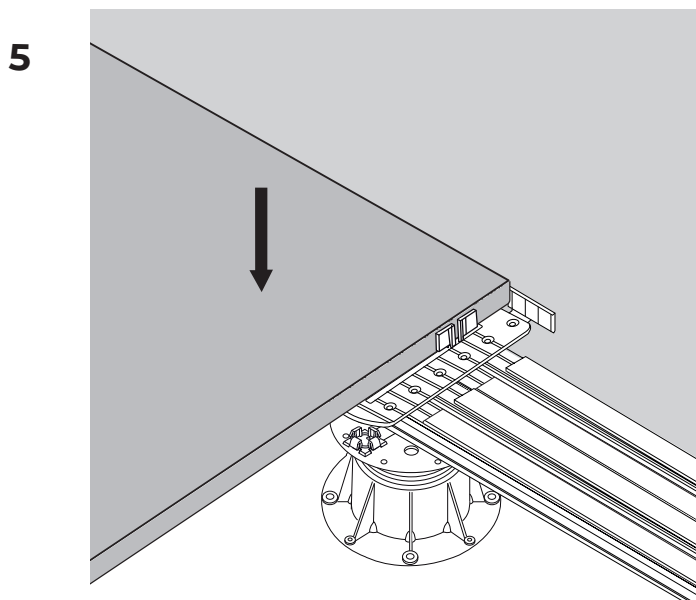
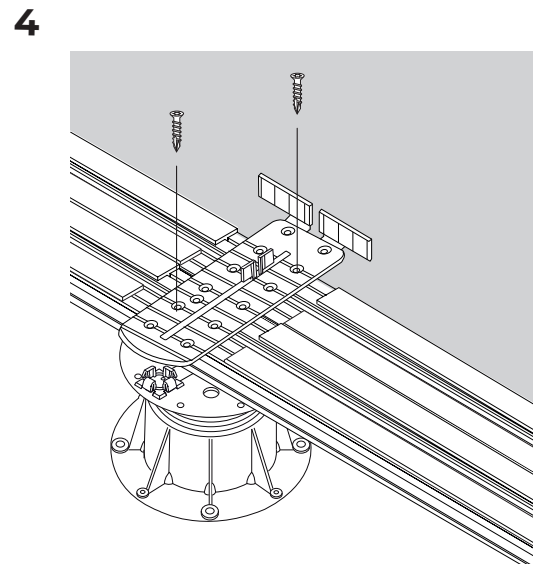
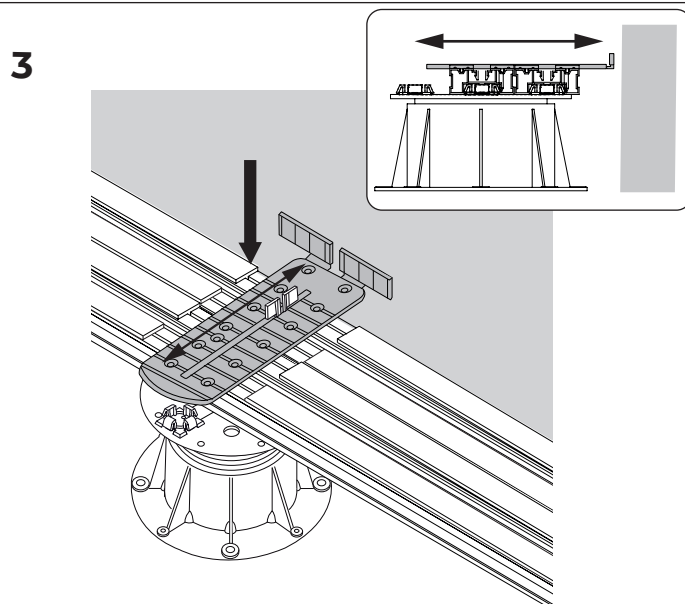
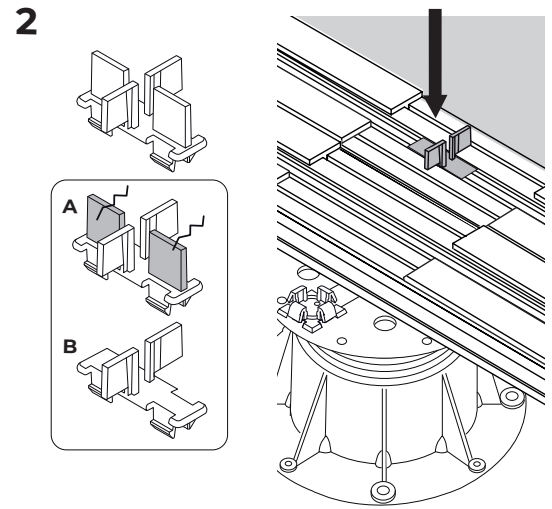
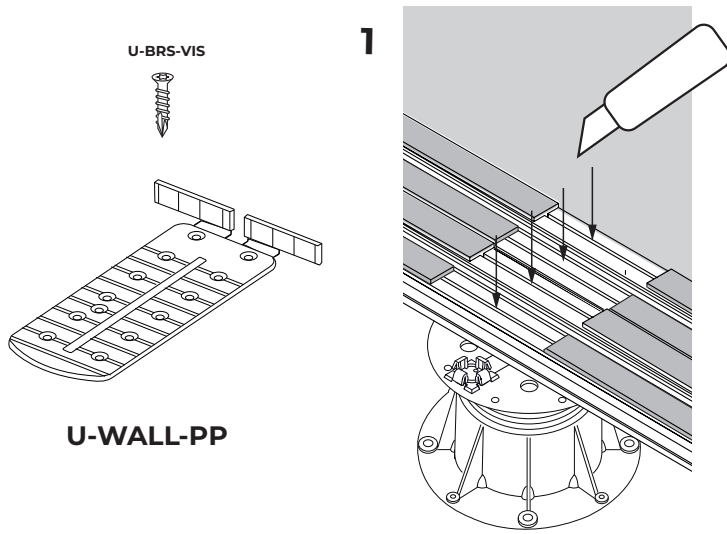

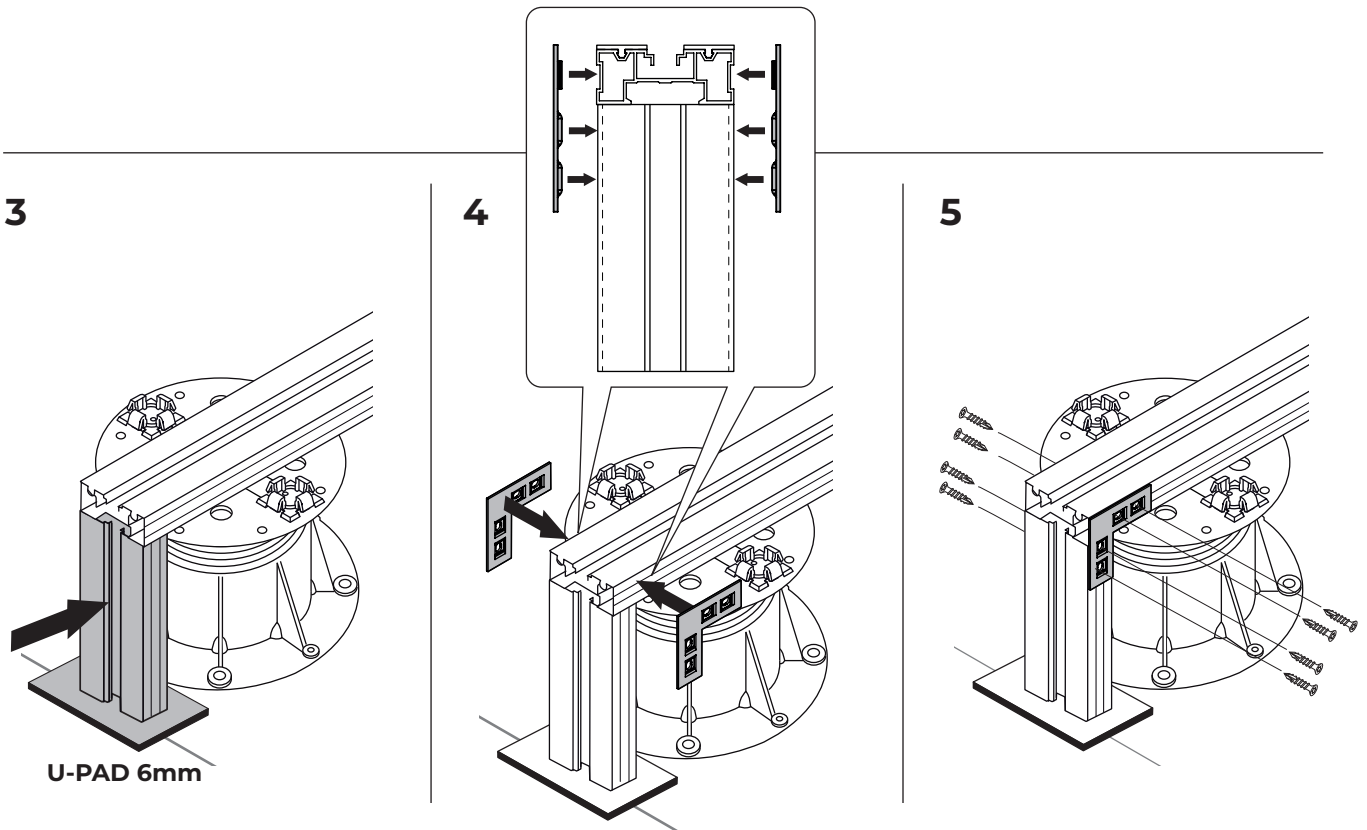
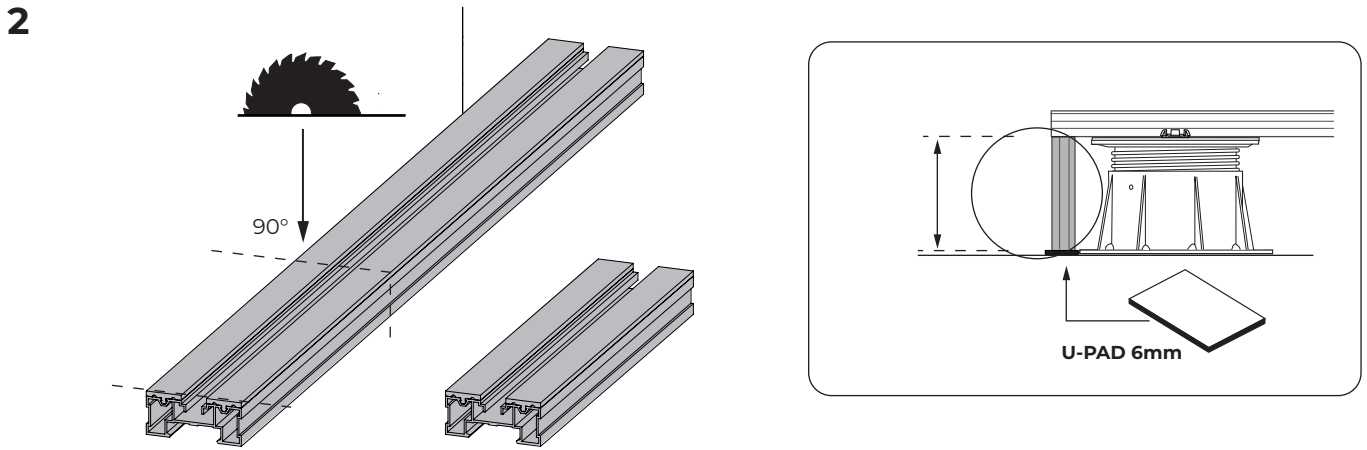
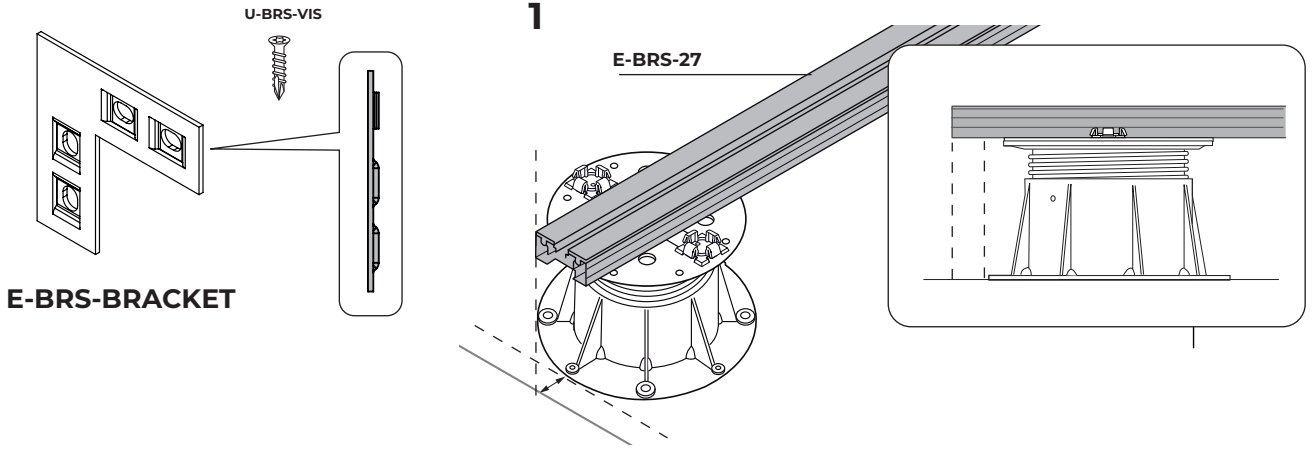

E-BRS-CONNECTION

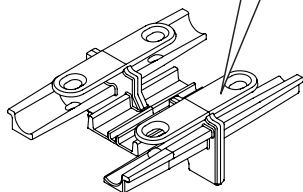
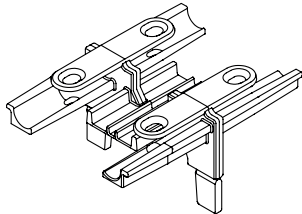
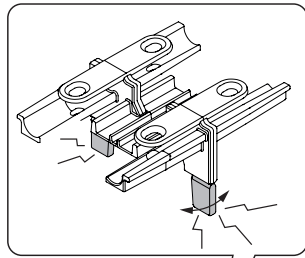

E-BRS-CONNECTION-41

E-BRS-CONNECTION-27

1

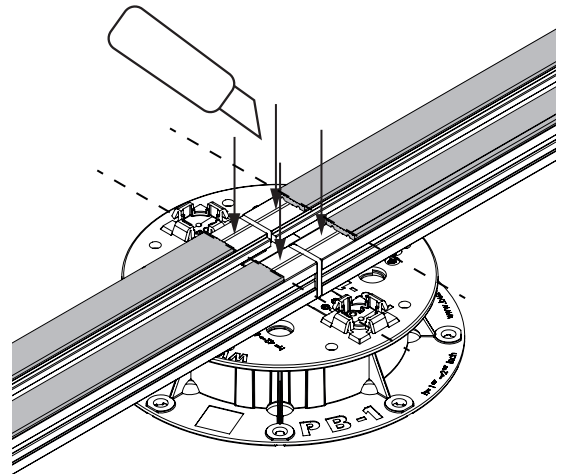

2

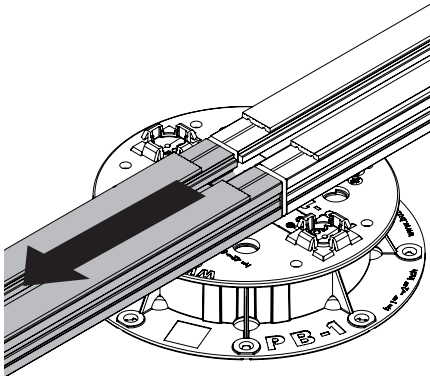

3

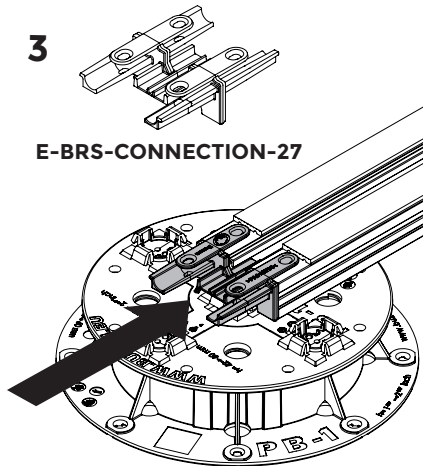

E-BRS-CONNECTION-27

4

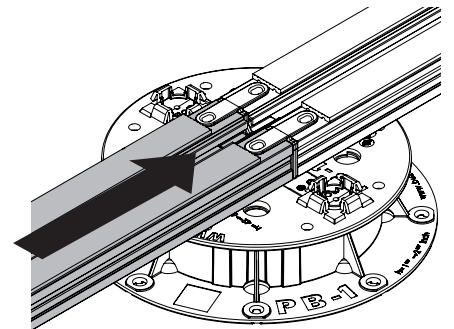

5

U-BRS-VIS

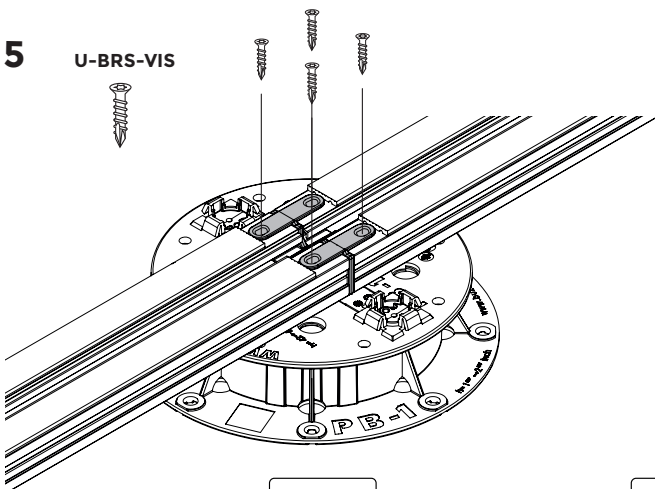

6

