

Buzon Pedestal International

4ème Avenue 25
Herstal 4040
Belgium

Tel: +32 42483983

e-mail: info@buzon-world.com

website: www.buzon-world.com



Agrément Certificate

24/7282

Product Sheet 2 Issue 1

BUZON PEDESTALS

PB PEDESTALS

This Agrément Certificate Product Sheet⁽¹⁾ relates to PB Pedestals, comprising recycled copolymer polypropylene (CPP) top plates, base plates, spacers, couplers and slope correctors, for use as support for decking and paving products for flat roofs, balconies, terraces, porches and exterior industrial surfaces. The product is designed for pedestrian use only and must not support moving and/or vibratory machinery or similar equipment.

(1) Hereinafter referred to as 'Certificate'.

The assessment includes

Product factors:

- compliance with Building Regulations
- compliance with additional regulatory or non-regulatory information where applicable
- evaluation against technical specifications
- assessment criteria and technical investigations
- uses and design considerations

Process factors:

- compliance with Scheme requirements
- installation, delivery, handling and storage
- production and quality controls
- maintenance and repair

Ongoing contractual Scheme elements†:

- regular assessment of production
- formal 3-yearly review



KEY FACTORS ASSESSED

- Section 1. Mechanical resistance and stability
- Section 2. Safety in case of fire
- Section 3. Hygiene, health and the environment
- Section 4. Safety and accessibility in use
- Section 5. Protection against noise
- Section 6. Energy economy and heat retention
- Section 7. Sustainable use of natural resources
- Section 8. Durability

The BBA has awarded this Certificate to the company named above for the product described herein. This product has been assessed by the BBA as being fit for its intended use provided it is installed, used and maintained as set out in this Certificate.

On behalf of the British Board of Agrément

Date of issue: 28 October 2024

Hardy Giesler
Chief Executive Officer

This BBA Agrément Certificate is issued under the BBA's Inspection Body accreditation to ISO/IEC 17020. Sections marked with † are not issued under accreditation.

The BBA is a UKAS accredited Inspection Body (No. 4345), Certification Body (No. 0113) and Testing Laboratory (No. 0357).

Readers MUST check that this is the latest issue of this Agrément Certificate by either referring to the BBA website or contacting the BBA directly.

The Certificate should be read in full as it may be misleading to read clauses in isolation.

Any photographs are for illustrative purposes only, do not constitute advice and should not be relied upon.

British Board of Agrément

1st Floor, Building 3, Hatters Lane
Croxley Park, Watford
Herts WD18 8YG

©2024

tel: 01923 665300
clientservices@bbacerts.co.uk
www.bbacerts.co.uk

SUMMARY OF ASSESSMENT AND COMPLIANCE

This section provides a summary of the assessment conclusions; readers should refer to the later sections of this Certificate for information about the assessments carried out.

Compliance with Regulations

Having assessed the key factors, the opinion of the BBA is that PB Pedestals, if installed, used and maintained in accordance with this Certificate, can satisfy or contribute to satisfying the relevant requirements of the following Building Regulations:



The Building Regulations 2010 (England and Wales) (as amended)

Requirement:	A1	Loading
Comment:		The product is acceptable. See section 1 of this Certificate.
Requirement:	B4(2)	External fire spread
Comment:		Roofs incorporating the product may be restricted by this Requirement. See section 2 of this Certificate.
Regulation:	7(1)	Materials and workmanship
Comment:		The product is acceptable. See sections 8 and 9 of this Certificate.
Regulation:	7(2)	Materials and workmanship
Comment:		The product is restricted by this Regulation. See section 2 of this Certificate.



The Building (Scotland) Regulations 2004 (as amended)

Regulation:	8(1)	Fitness and durability of materials and workmanship
Comment:		The product is acceptable. See sections 8 and 9 of this Certificate.
Regulation:	8(3)	Fitness and durability of materials and workmanship
Comment:		The product is restricted by this Regulation. See section 2 of this Certificate.
Regulation:	9	Building standards - construction
Comment:	1.1(a)(b)	Structure The product is acceptable, with reference to clauses 1.1.1 ⁽¹⁾⁽²⁾ and 1.1.2 ⁽¹⁾⁽²⁾ . See section 1 of this Certificate.
Standard:	2.7	Spread on external walls
Comment:		The product is restricted by this Standard, with reference to clause 2.7.2 ⁽¹⁾⁽²⁾ . See section 2 of this Certificate.
Standard:	2.8	Spread from neighbouring buildings
Comment:		Roofs incorporating the product may be restricted by this Standard, with reference to clause 2.8.1 ⁽¹⁾⁽²⁾ . See section 2 of this Certificate.
Standard:	7.1(a)	Statement of sustainability
Comment:		The product can contribute to satisfying the relevant Requirements of Regulation 9, Standards 1 to 6, and therefore will contribute to a construction meeting a bronze level of sustainability as defined in this Standard.
Regulation:	12	Building standards - conversion
Comment:		All comments given for the product under Regulation 9, Standards 1 to 6, also apply to this Regulation, with reference to clause 0.12.1 ⁽¹⁾⁽²⁾ and Schedule 6 ⁽¹⁾⁽²⁾ .

(1) Technical Handbook (Domestic).

(2) Technical Handbook (Non-Domestic).



The Building Regulations (Northern Ireland) 2012 (as amended)

Regulation:	23(1)(a)(i)	Fitness of materials and workmanship
Comment:	(iii)(b)(i)	The product is acceptable. See sections 8 and 9 of this Certificate.
Regulation:	23(2)	Fitness of materials and workmanship
Comment:		The product is restricted by this Regulation. See section 2 of this Certificate.
Regulation:	30	Stability
Comment:		The product is acceptable. See section 1 of this Certificate.
Regulation:	36(b)	External fire spread
Comment:		Roofs incorporating the product may be restricted by this Regulation. See section 2 of this Certificate.

Additional Information

NHBC Standards 2024

In the opinion of the BBA, PB Pedestals, if installed, used and maintained in accordance with this Certificate, can satisfy or contribute to satisfying the relevant requirements in relation to *NHBC Standards*, Chapter 7.1 *Flat roofs, terraces and balconies*.

Fulfilment of Requirements

The BBA has judged PB Pedestals to be satisfactory for use as described in this Certificate. The product has been assessed as support for decking and paving products for flat roofs, balconies, terraces, porches and exterior industrial surfaces. The product is designed for pedestrian use only and must not support moving and/or vibratory machinery or similar equipment.

ASSESSMENT

Product description and intended use

The Certificate holder provided the following description for the product under assessment. PB Pedestals (see Figures 1 and 2) comprise recycled copolymer polypropylene (CPP) and consists of:

- top plate — screwed directly onto the base plate or the couplers. The top plate has a diameter of 170 mm and a minimum wall thickness of 4 mm. It can be fitted with various components (see Table 1) to support complex shaped tiles and different applications such as stone pavers and timber decking
- couplers — used to extend the height of the pedestals to the required finish floor, up to 955 mm. The couplers have a minimum wall thickness of 4 mm
- base plate — with a minimum wall thickness of 4 mm, positioned or fixed to compatible substrates. The base plate has 8 fixing holes for screws or bolts. The base diameter is 197 mm
- slope correctors — the U-PH5 slope corrector is placed under the base of the pedestal and allows precise adjustment in increments of 0.5% for slopes between 0-5%. For some of the pedestals, it is integrated into the pedestal assembly, and for the remaining types, it can be fixed at the bottom of the pedestal.

Figure 1 PB Pedestals Exploded



The product has the nominal characteristics given in Table 1.

Table 1 Nominal characteristics and components of PB Pedestals

Pedestal ID	Pedestal type	Characteristic (unit)			
		Height (mm)	Top plate, \varnothing (mm)	Base plate, \varnothing (mm)	Components
PB-00	Fixed	15	170	197	—
PB-S12	Adjustable	12-18	170	197	PB top plate PB base plate
PB-S18	Adjustable	18 - 28	170	197	PB top plate PB base plate
PB-01	Adjustable	28 - 42	170	197	PB top plate PB base plate
PB-1	Adjustable	42 - 60	170	197	—
PB-2	Adjustable	60 - 90	170	197	PB top plate PB base plate
PB-3	Adjustable	90 - 145	170	197	PB top plate PB base plate
PB-4	Adjustable	145 - 245	170	197	PB top plate PB base plate
PB-5	Adjustable	230 - 315	170	197	1 PB-3 top plate 1 coupler PB-C1 1 PB-4 base plate
PB-6	Adjustable	285 - 367	170	197	1 PB-4 top plate 1 coupler PB-C1 1 PB-4 base plate
PB-7	Adjustable	365 - 480	170	197	1 PB-4 top plate 1 coupler PB-C2 1 PB-4 base plate
PB-8	Adjustable	480 - 595	170	197	1 PB-4 top plate 1 coupler PB-C1 1 coupler PB-C2 1 PB-4 base plate
PB-9	Adjustable	560 - 715	170	197	1 PB-4 top plate 1 coupler PB-C1 1 coupler PB-C2 1 PB-4 base plate
PB-10	Adjustable	675 - 830	170	197	1 PB-4 top plate 1 coupler PB-C1 2 coupler PB-C2 1 PB-4 base plate
PB-11	Adjustable	755 - 955	170	197	1 PB-4 top plate 3 coupler PB-C2 1 PB-4 base plate

Figure 2 PB Pedestals — illustrations

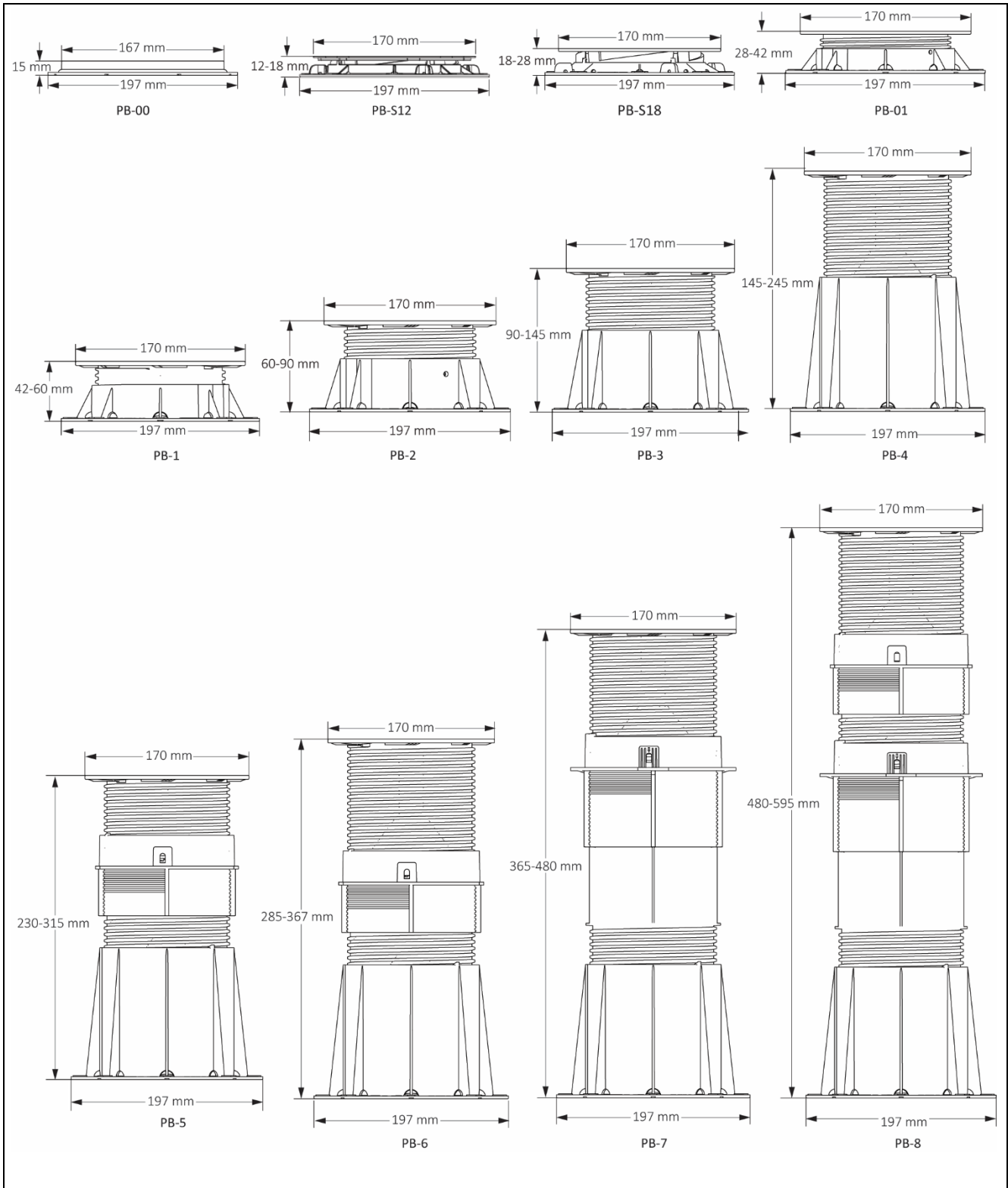
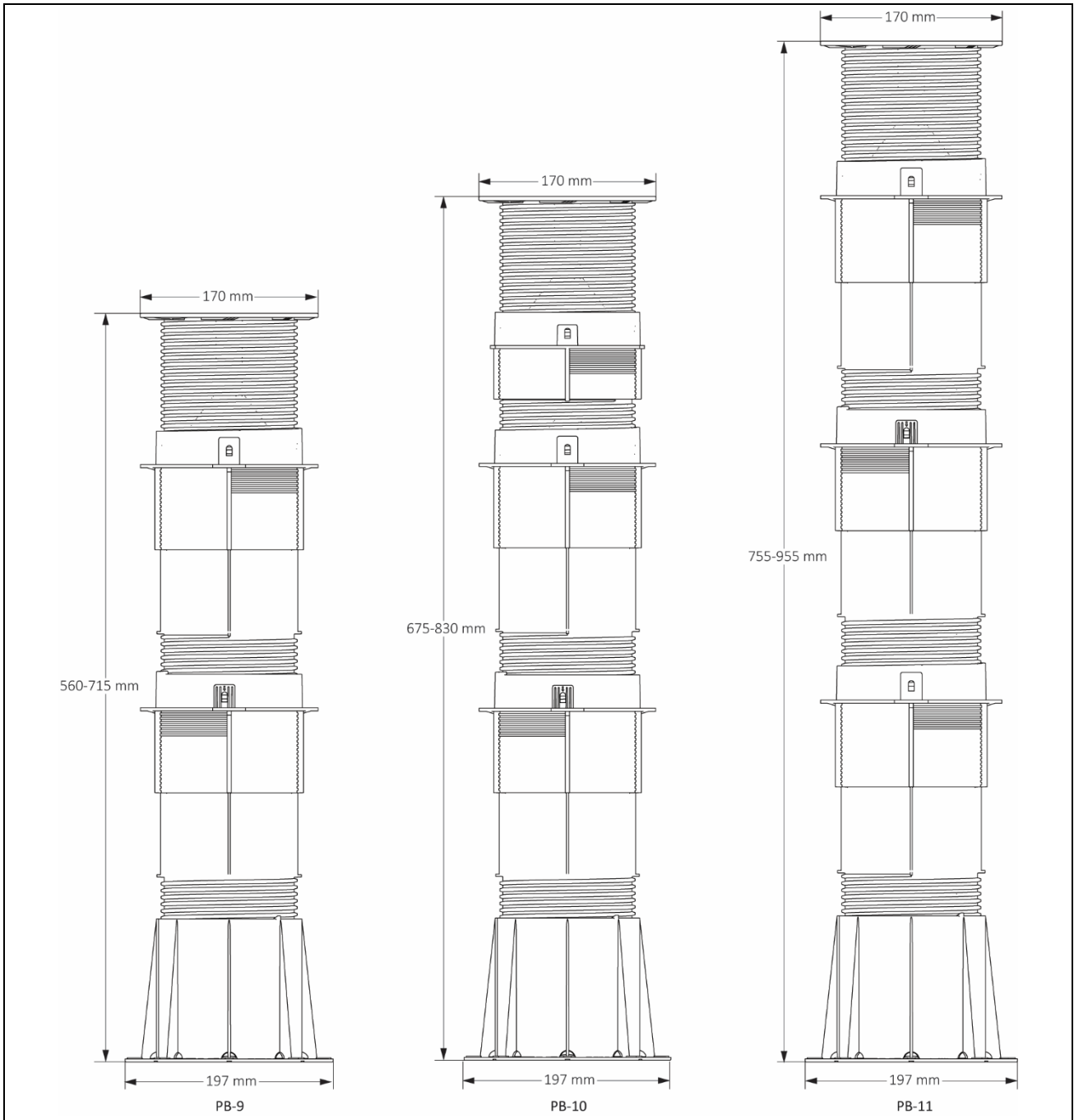

Figure 2 PB Pedestals — illustrations (continued)



Ancillary Items

The Certificate holder recommends the following ancillary items for use with the product, but these materials have not been assessed by the BBA and are outside the scope of this Certificate:

- spacer tabs (see Figure 3) — available in thicknesses of 2, 3, 4.5, 6, 8 and 10 mm. Spacer tabs provide proper alignment of the pavers placed on top of the pedestals.
- shims — to stabilise the paver, provide additional acoustic comfort, and compensate for variations in paver thickness. Shims are 1 or 2 mm thick with maltase-cross shaped levellers and are available as U-E10 or U-E20 (see Figure 4)
- batten holder — firmly holds the joists supporting the deck boards. There are two types: fixed (maximum size of batten is 65 mm) and universal (maximum size of batten up to 90 mm) (see Figure 5). The minimum thickness of the joist is 30 mm.

Figure 3 Spacer tabs

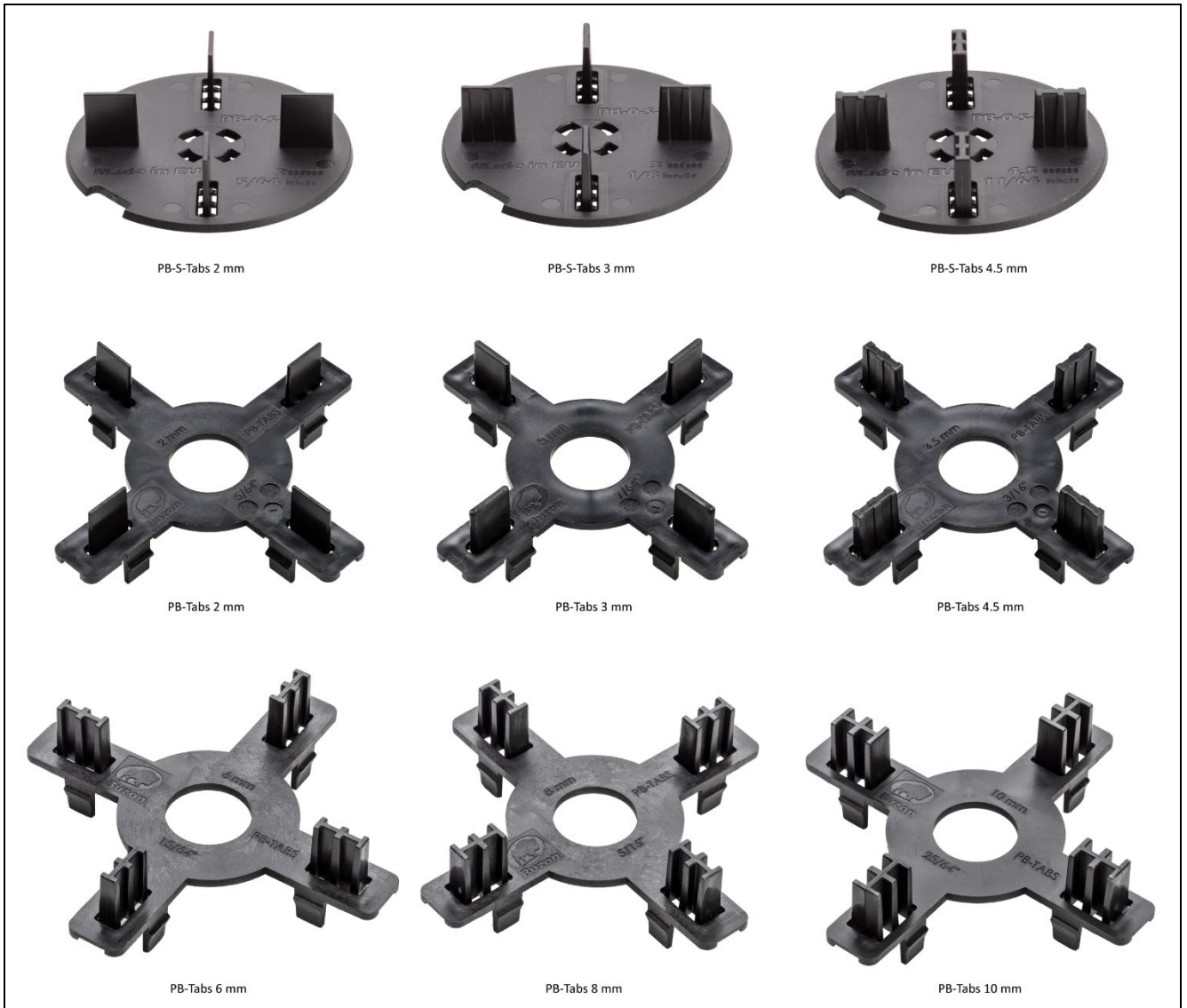

Figure 4 Shims

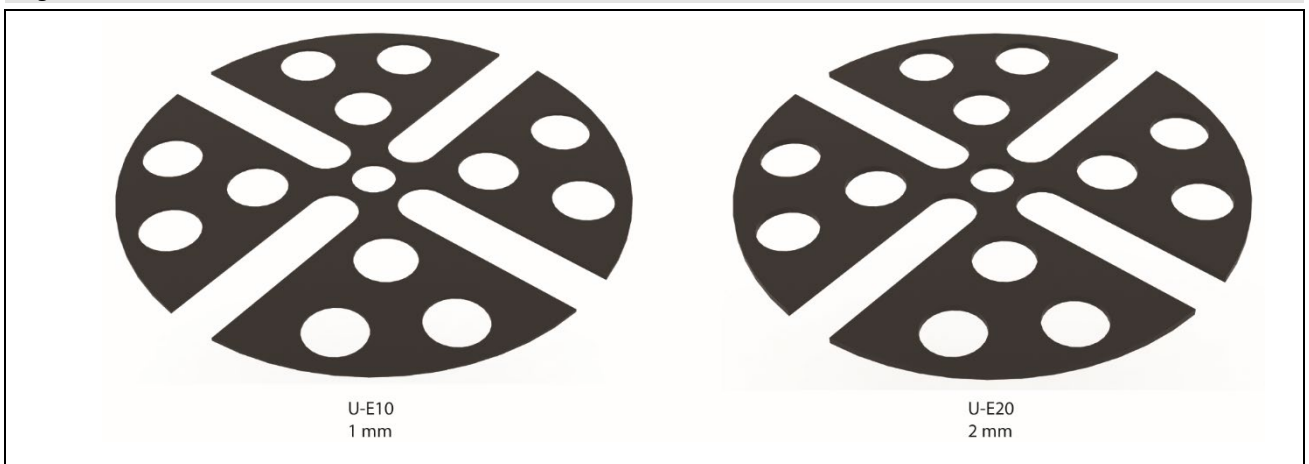
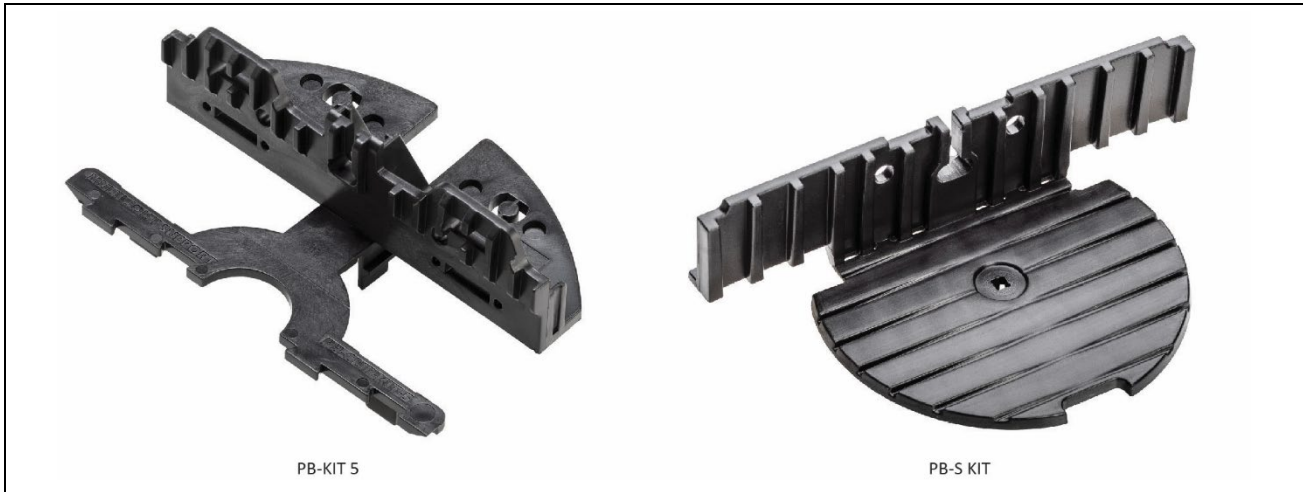

Figure 5 Batten holder



Definitions for products and applications inspected

The pedestals are designed for pedestrian use only. The pedestals are not designed to support moving/vibratory machines and equipment, including maintenance, cleaning or vehicular traffic.

Product assessment – key factors

The product was assessed for the following key factors, and the outcome of the assessment is shown below. Conclusions relating to the Building Regulations apply to the whole of the UK unless otherwise stated.

1 Mechanical resistance and stability

Data were assessed for the following characteristics.

1.1 Strength and stability

1.1.1 PB Pedestals were subjected to short-term characteristic compressive loads based on the specifications to EN 12825 : 2001. The loads were applied on the whole surface area of the pedestal (1/1). The characteristic failure loads are summarized in Table 2 of this Certificate.

Table 2 PB Pedestals – short-term characteristic failure load values

Product assessed	Assessment method	Tested height (mm)	Requirement	Result ⁽¹⁾
				Failure Load at 23°C (kN)
				Test (1/1)
PB-00	Based on the specifications to EN 12825 : 2001	15	Value achieved	53.4
PB-01		42		10.72
PB-1		60		13.97
PB-2		90		13.89
PB-3		145		15.78
PB-4		245		12.43
PB-5		315		12.56
PB-6		367		9.21
PB-7		480		11.95
PB-8		595		10.3
PB-9		722		10.16
PB-10		830		9.65
PB-11	955	9.79		
PB-S12	18	26.65		
PB-S18	28	21.27		

(1) Maximum load per one pedestal not to exceed the value of 1/1.

1.1.2 On the basis of data assessed, the product has the compressive strength as stated in Table 2. The values in Table 2 must be divided by the Factor of Safety of 3 to find the design resistance of each pedestal.

1.2 Behaviour under loading

An evaluation of creep behaviour was assessed. The product is not deemed to deform non-uniformly due to creep behaviour.

2 Safety in case of fire

Data were assessed for the following characteristics.

2.1 External fire spread

2.1.1 When tested to DD CEN/TS 1187 : 2012, Test 4, the constructions given in Table 3 of this Certificate achieved a classification under BS EN 13501-5 : 2016 of B_{ROOF}(t4).

Table 3 External fire spread classifications

Product assessed			Assessment method	Reinforcement	Reaction to fire classification
Construction from base to top					
Supporting deck	Wood particle board	16 mm thickness 680 kg·m ⁻³ density	Tested to DD CEN/TS 1187 : 2012, Test 4 Reaction to fire classification to BS EN 13501-1 : 2016 ⁽¹⁾⁽²⁾	—	—
Vapour barrier	Self-adhesive bituminous air and vapour control layer with a polyester-coated aluminium foil and glass fleece reinforcement and a mineral finish	2.5 mm thickness 3000 g·m ⁻² surface weight		200 g·m ⁻² polyester-coated aluminium foil and 60 g·m ⁻² glass fleece	E
Adhesive	PUR adhesive	75 g·m ⁻² applied amount with twin cartridge applicator gun		—	—
Insulation layer	Polyisocyanurate (PIR) insulation boards with an aluminium facing and backing	120 mm thickness 30 kg·m ⁻³ density facing aluminium 37 g·m ⁻² backing aluminium 37 g·m ⁻²		—	E
Roof covering – first layer	Self-adhesive elastomeric underlayer with a glass lattice reinforcement	3 mm thickness 3500 g·m ⁻² surface weight		200 g·m ⁻² glass lattice	—
Roof covering – top layer	Torched-on elastomeric underlayer with a spunbond polyester reinforcement and a charcoal mineral finish	5.2 mm thickness 6500 g·m ⁻² surface weight		250 g·m ⁻² spunbond polyester	—
Pedestal system	PB-3 (loosely placed on the top layer) consisting of PB top, base, spacer tabs 10 mm h17 and U-E20 SBR	90 mm height 170 mm top diameter 197 mm bottom diameter 492 g mass		—	B _{ROOF} (t4)
Ceramic tiles	Loosely laid onto the pedestals	20 mm thickness 417 x 417 mm and 835 x 417 mm 54000 g·m ⁻² surface weight		—	A1

(1) Fire test and classification reports, reference 20958A and 20958B respectively, conducted by Warringtonfire Gent. Reports are available from the Certificate holder.

(2) Fields of Application are included in the above reports:

Direct Field of Application:

- Range of roof pitches: ≤ 10°

- Deck: wood particle board (16 mm thick or more and 680 kg·m⁻³ density or more)

Extended Field of Application:

- Range of tiles: 20 mm thick or more, 10 mm or less joints, 54000 g·m⁻² surface weight and class A1 reaction to fire

- Range of pedestals can be 90 mm or more height.

2.1.2 On the basis of data assessed, when classified to BS EN 13501-5 : 2016, the construction incorporating the pedestals given in Table 3 of this Certificate, achieved external fire exposure resistance classification B_{ROOF}(t4) for slopes below or equal to 10° and so, with the exceptions given in sections 2.2.2 to 2.2.4, is unrestricted in terms of proximity to a relevant boundary by the documents supporting the national Building Regulations. Restrictions may apply at junctions with compartment walls.

2.1.3 The classification and permissible areas of use of other specifications must be confirmed by reference to the requirements of the documents supporting the national Building Regulations.

2.2 Reaction to fire

2.2.1 The Certificate holder has not declared a fire classification for the product in accordance with BS EN 13501-1 : 2018.

2.2.2 On the basis of data assessed, in Scotland, the product must not be used on balconies on buildings with a storey 11 m or more above the ground.

2.2.3 On the basis of data assessed, in England and Wales, the product must not be used on balconies on buildings that have a storey at least 18 m above ground level and which contain one or more dwellings, an institution, a room for residential purposes (excluding, in Wales only, any room in a hostel, hotel or boarding house), student accommodation, care homes, sheltered housing, hospitals or dormitories in boarding schools. Additionally, in England, the product must not be used on balconies of residential buildings with a storey 11 m or more in height.

2.2.4 On the basis of the data assessed, in Northern Ireland, the product must not be used on balconies on buildings that have a storey at least 18 m above ground level and which contain one or more dwellings, an institution, a room for residential purposes (excluding any room in a hostel, hotel or boarding house), student accommodation, care homes, nursing homes, sheltered housing, hospitals, dormitories in boarding schools and places of lawful detention.

3 Hygiene, health and the environment

Data were assessed for the following characteristics.

3.1 Resistance to chemicals

3.1.1 The material representative samples were stored in accordance with ASTM D 543-14 and were subjected to tensile tests in accordance with DIN EN ISO 527-1 : 2012-06, the changes in volume, mass and dimensions were also measured. The density was measured in accordance with DIN EN ISO 1182 : 2013-04. Results are given in Tables 4 and 5 of this Certificate.

Table 4 Tensile properties

Material assessed	Assessment method	Requirement	Result ⁽¹⁾
Recycled copolymer polypropylene (CPP)	DIN EN ISO 527-1 : 2012-06	Value achieved	Tensile modulus 2040 ± 25 MPa
	Control sample		Tensile stress 18.9 ± 0.7 MPa
			Elongation at break 18.5 ± 5.8 (%)
Recycled copolymer polypropylene (CPP)	DIN EN ISO 527-1 : 2012-06	Value achieved	Tensile modulus 1970 ± 31 MPa
	(7 days at 50°C in 3% Sulfuric acid)		Tensile stress 18.9 ± 0.7 MPa
			Elongation at break 20.3 ± 6.7 (%)
Recycled copolymer polypropylene (CPP)	DIN EN ISO 527-1 : 2012-06	Value achieved	Tensile modulus 1960 ± 23 MPa
	(7 days at 50°C in 10% Sodium Chloride)		Tensile stress 19.3 ± 0.5 MPa
			Elongation at break 18.9 ± 5.3 (%)
Recycled copolymer polypropylene (CPP)	DIN EN ISO 527-1 : 2012-06	Value achieved	Tensile modulus 1920 ± 19 MPa
	(7 days at 50°C in 5% Sodium Hypochlorite)		Tensile stress 19.4 ± 0.4 MPa
			Elongation at break 14.1 ± 2.5 (%)

(1) Mean values ± standard deviation.

Table 5 Dimensional stability

Material assessed	Assessment method ⁽¹⁾	Requirement	Result (%) ⁽¹⁾
Recycled copolymer polypropylene (CPP)	ASTM D543-14 (7 days at 50°C in 3% Sulfuric acid)	Value achieved	Thickness
			-0.04 ± 0.07
			Width
			0.13 ± 0.16
Recycled copolymer polypropylene (CPP)	ASTM D543-14 (7 days at 50°C in 10% Sodium Chloride)	Value achieved	Weight change
			0.24 ± 0.09
			Volume change
			0.25 ± 0.15
Recycled copolymer polypropylene (CPP)	ASTM D543-14 (7 days at 50°C in 5% Sodium Hypochlorite)	Value achieved	Thickness
			-0.27 ± 0.38
			Width
			0.1 ± 0.1
Recycled copolymer polypropylene (CPP)	ASTM D543-14 (7 days at 50°C in 5% Sodium Hypochlorite)	Value achieved	Weight change
			0.21 ± 0.31
			Volume change
			0.19 ± 0.41
Recycled copolymer polypropylene (CPP)	ASTM D543-14 (7 days at 50°C in 5% Sodium Hypochlorite)	Value achieved	Thickness
			-0.12 ± 0.31
			Width
			0.07 ± 0.15
Recycled copolymer polypropylene (CPP)	ASTM D543-14 (7 days at 50°C in 5% Sodium Hypochlorite)	Value achieved	Weight change
			0.23 ± 0.16
			Volume change
			0.27 ± 0.15

(1) Mean values ± standard deviation.

3.1.2 On the basis of data assessed, all tested chemicals caused only minor variation in dimension, weight and volume. Storage in all chemicals caused no changes in appearance visible to the naked eye.

4 Safety and accessibility in use

Not applicable.

5 Protection against noise

Not applicable.

6 Energy economy and heat retention

Not applicable.

7 Sustainable use of natural resources

7.1 Reuse and recyclability

The product is manufactured from CPP, which can be recycled.

8 Durability

8.1 The potential mechanisms for degradation and the known performance characteristics of the materials in the product were assessed.

8.2 Service life

Under normal service conditions, the product will have a life in excess of 30 years, provided it is designed, installed and maintained in accordance with this Certificate and the Certificate holder's instructions.

Information provided by the Certificate holder was assessed for the following factors:

9 Design, installation, workmanship and maintenance

9.1 Design

9.1.1 The design process was assessed by the BBA and the following requirements apply in order to satisfy the performance assessed in this Certificate.

9.1.2 Designers, planners, contractors and/or installers must ensure that the installation of PB Pedestals is in accordance with the Certificate holder's instructions and the information given in this Certificate.

9.1.3 The suitability of the floor/deck to support the loads and the expected displacement in both the short- and long-term must be considered by a suitably experienced and competent individual.

9.1.4 It is a responsibility of the designer to ensure that the pedestals are not cut in any situation.

9.1.5 A suitably experienced and competent individual must undertake the calculations to the relevant code of practice, including:

- the characteristic values of the imposed loads for flat roofs, balconies, terraces and porches in accordance with BS EN 1991-1-1 : 2002 and its UK National Annex, and the characteristic values of the imposed loads for areas of industrial use in accordance with PD 6688-1-1 : 2011
- the characteristic values of the self-weight and finishes for floors, roofs, balconies in accordance with BS EN 1991-1-1 : 2002 and its UK National Annex
- the ultimate load applied on each pedestal in accordance with either equation 6.10 or less favourable equations 6.10a and 6.10b of BS EN 1990 : 2023 and its UK National Annex based on self-weight of the floor and finishes, and imposed loads as defined in first and second bullet points mentioned above
- take into account the short- and long-term displacement of each pedestal mentioned in Table 1 of this Certificate. Also, take into account the short- and long-term deflection of substrates
- an assessment of the robustness of the design to ensure if any locking key, positioned at one corner of a slab, inadvertently was unlocked due to foreseen or unforeseen events (incorrect installation, impact, or survival after an accidental event) to prevent collapse of the floor or roof or balcony.

9.2 Installation

9.2.1 Installation instructions provided by the Certificate holder were assessed and judged to be appropriate and adequate.

9.2.2 Installation must be carried out in accordance with this Certificate and the Certificate holder's instructions. A summary of instructions and guidance is provided in Annex A of this Certificate.

9.2.3 PB Pedestals must be transported in their original packaging. It must be ensured that no damage occurs during transport and the pedestal components must be checked before installation. Also, they must be handled with care during installation and to avoid damage by being dropped.

9.3 Workmanship

Practicability of installation was assessed by the BBA, on the basis of the Certificate holder's information and a site visit to witness an installation in progress. To achieve the performance described in this Certificate, installation of the product must be carried out by a competent general builder, or a contractor experienced with this type of product.

9.4 Maintenance and repair

9.4.1 As the product is confined within the floor void and has suitable durability. Maintenance is not required.

The following requirements apply in order to satisfy the performance assessed in this Certificate:

9.4.2 The pedestals are manufactured from CPP and do not require maintenance in general.

9.4.3 If the pedestals need to be replaced, the guidelines provided in the Certificate holder's manual must be followed.

10 Manufacture

10.1 The production processes for the product have been assessed, and provide assurance that the quality controls are satisfactory according to the following factors:

10.1.1 The manufacturer has provided documented information on the materials, processes, testing and control factors.

10.1.2 The quality control operated over batches of incoming materials has been assessed and deemed appropriate and adequate.

10.1.3 The quality control procedures and product testing to be undertaken have been assessed and deemed appropriate and adequate.

10.1.4 The process for management of non-conformities has been assessed and deemed appropriate and adequate.

10.1.5 An audit of each production location was undertaken, and it was confirmed that the production process was in accordance with the documented process, and that equipment has been properly tested and calibrated.

† 10.2 The BBA has undertaken to review the above measures on a regular basis through a surveillance process, to verify that the specifications and quality control operated by the manufacturer are being maintained.

11 Delivery and site handling

11.1 The Certificate holder stated that the product is delivered to site in packaging bearing the details of components including type and dimensions, and the BBA logo incorporating the number of this Certificate.

Supporting information in this Annex is relevant to the product but has not formed part of the material assessed for the Certificate.

Construction (Design and Management) Regulations 2015

Construction (Design and Management) Regulations (Northern Ireland) 2016

Information in this Certificate may assist the client, designer (including Principal Designer) and contractor (including Principal Contractor) to address their obligations under these Regulations.

Management Systems Certification for production

The management system of the manufacturer has been assessed and registered as meeting the requirements of BS EN ISO 9001 : 2015 by SGS (Certificate BE 18/819943236)

Additional information on installation

A.1 Good site practice must be observed to prevent damage to the components of the pedestal.

A.2 PB Pedestals can be installed on a wide range of solid, even and stable substrates, such as concrete slabs, cement screeds, waterproof membranes and insulation panels. Substrates must be free of dust, dirt and waste material. Use of wedges under pedestals must be avoided. The designer must confirm layout, position and height of the decking or pavers. Installation must be strictly in accordance with the Certificate's holder's Installation Manual.

A.3 For installation, mason wire is used to set out the first line, and a second line, perpendicular to the first. Chalk can be used to draw lines on the substrate. After setting out the initial two lines, grid lines can be extended to mark the location of the pedestals. The dimensions of grid lines depend on the dimensions of the paver used. Further guidelines may be found in Certificate holder's Installation Manual.

A.4 Three pedestals need to be placed at the junction of the two initially drawn lines, and checked with a leveller to ensure the heads of the pedestals are at the same height and level (see Figure 5.1). If necessary, accessories such as spacer tabs or shims can be used, such as to compensate for the variation in paver thickness. The paver is then balanced and levelled on the three pedestals (see Figure 5.2).

A.5 A fourth pedestal can then be inserted (see Figure 5.3) and its head level checked. The pedestal's head and paver must be perfectly level.

Figure 5 Pedestal installation

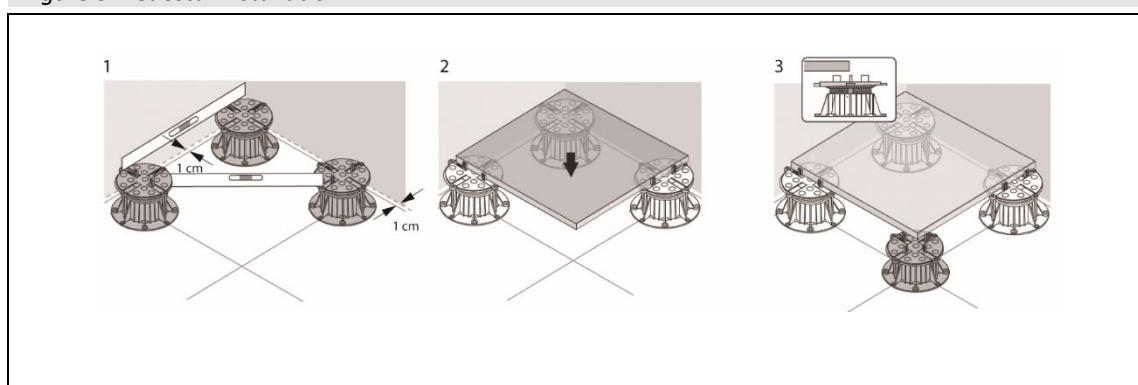

A.6 With the first paver installed, the next pedestal must be placed (in line with the first paver). The level is checked for the two most recently placed pedestals under the first paver, and the newly placed pedestal (as shown in Figure 6). The second paver is then balanced on the three checked pedestals, with the information in sections A.5 and A.6 followed regarding levelling and the placement of the fourth pedestal. In the same manner, all pavers are placed along the wall, ensuring all pavers are level. If pavers are not level, accessories mentioned in the *Product description and intended use* section of this Certificate may be used.

Figure 6 Pedestal installation cont.

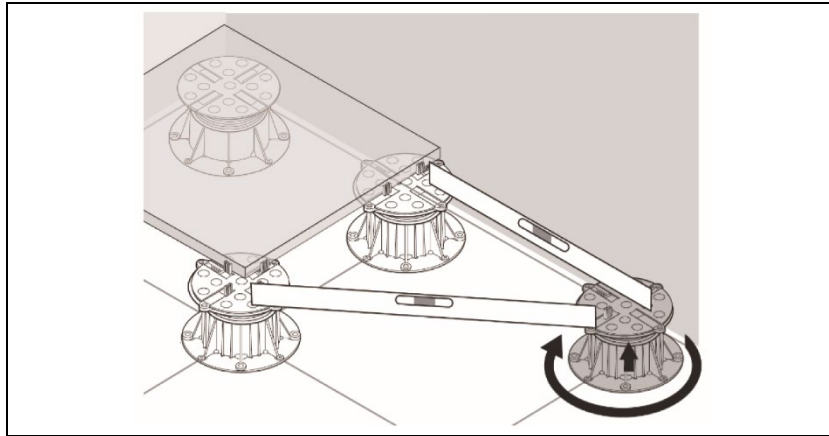

- A.7 With the completion of the first row of pavers, another row, perpendicular to the first row, must be executed in the same manner as described previously. Further details can be found in the Certificate holder's Installation Manual.
- A.8 If the design demands a slope, the slope corrector can be fixed on the pedestal. Spacer tabs and shims can be used with the product if needed. Further details can be requested from the Certificate holder.
- A.9 Typically, four pedestals placed at the edges are used to support each paver. If needed, one extra pedestal in the middle of the paver may be used for improved stability. In the case of large pavers, it is recommended to use the extra pedestal. Installation must be in accordance with the installation manual from the paver manufacturer.
- A.10 If wood is used for the system, then batten holders must be used. The type of batten holder will depend on the dimension of wood joist or batten used. Wood joists or battens placed on pedestals must be fixed with screws.
- A.11 After installation of each paver, the alignment must be checked.
- A.12 Installation must be in accordance with the Certificate holder's instructions and this Certificate.

Bibliography

ASTM D 543-14 *Standard Practices For Evaluation The Resistance Of Plastics To Chemical Reagents*

BS EN 1990 : 2023 *Eurocode — Basis of structural and geotechnical design*

UK to BS EN 1990 : 2023 UK National Annex to *Eurocode — Basis of structural and geotechnical design*

BS EN 1991-1-1 : 2002 *Eurocode 1 — Actions on structures — General actions — Densities, self-weight, imposed loads for buildings*

NA to BS EN 1991-1-1 : 2002 UK National Annex to *Eurocode 1 — Actions on structures — General actions — Densities, self-weight, imposed loads for buildings*

BS EN 13501-1 : 2007 *Fire classification of construction products and building elements — Classification using data from reaction to fire tests*

BS EN 13501-5 : 2016 *Fire classification of construction products and building elements — Classification using data from external fire exposure to roofs tests*

BS EN ISO 9001 : 2015 *Quality management systems — Requirements*

DIN EN ISO 527-1 : 2012-06 *Plastics — Determination of tensile properties — General principles*

DIN EN ISO 1182 : 2013-04 *Reaction to fire tests for products — Non-combustibility test*

DD CEN/TS 1187 : 2012 *Test methods for external fire exposure to roofs*

EN 12825 : 2001 *Raised access floors*

PD 6688-1-1 : 2011 *Recommendations for the design of structures to BS EN 1991-1-1*

Conditions

1 This Certificate:

- relates only to the product that is named and described on the front page
- is issued only to the company, firm, organisation or person named on the front page – no other company, firm, organisation or person may hold or claim that this Certificate has been issued to them
- has to be read, considered and used as a whole document – it may be misleading and will be incomplete to be selective
- is copyright of the BBA
- and any matter arising out of or in connection with it or its subject matter (including non-contractual disputes or claims) is governed by and construed in accordance with the law of England and Wales.
- the courts of England and Wales shall have exclusive jurisdiction to settle any matter arising out of or in connection with this Certificate or its subject matter (including non-contractual disputes or claims).

2 Publications, documents, specifications, legislation, regulations, standards and the like referenced in this Certificate are those that were current and/or deemed relevant by the BBA at the date of issue or reissue of this Certificate.

3 This Certificate will be displayed on the BBA website, and the Certificate Holder is entitled to use the Certificate and Certificate logo, provided that the product and its manufacture and/or fabrication, including all related and relevant parts and processes thereof:

- are maintained at or above the levels which have been assessed and found to be satisfactory by the BBA
- continue to be checked as and when deemed appropriate by the BBA under arrangements that it will determine
- are reviewed by the BBA as and when it considers appropriate.

4 The BBA has used due skill, care and diligence in preparing this Certificate, but no warranty is provided.

5 In issuing this Certificate the BBA is not responsible and is excluded from any liability to any company, firm, organisation or person, for any matters arising directly or indirectly from:

- the presence or absence of any patent, intellectual property or similar rights subsisting in the product or any other product
- the right of the Certificate holder to manufacture, supply, install, maintain or market the product
- actual installations of the product, including their nature, design, methods, performance, workmanship and maintenance
- any works and constructions in which the product is installed, including their nature, design, methods, performance, workmanship and maintenance
- any loss or damage, including personal injury, howsoever caused by the product, including its manufacture, supply, installation, use, maintenance and removal
- any claims by the manufacturer relating to UKCA marking and CE marking.

6 Any information relating to the manufacture, supply, installation, use, maintenance and removal of this product which is contained or referred to in this Certificate is the minimum required to be met when the product is manufactured, supplied, installed, used, maintained and removed. It does not purport in any way to restate the requirements of the Health and Safety at Work etc. Act 1974, or of any other statutory, common law or other duty which may exist at the date of issue or reissue of this Certificate; nor is conformity with such information to be taken as satisfying the requirements of the 1974 Act or of any statutory, common law or other duty of care.

Buzon Pedestal International

4ème Avenue 25
Herstal 4040
Belgium

Tel: +32 42483983

e-mail: info@buzon-world.com

website: www.buzon-world.com



Agrément Certificate

24/7282

Product Sheet 1 Issue 1

BUZON PEDESTALS

DPH PEDESTALS

This Agrément Certificate Product Sheet⁽¹⁾ relates to DPH Pedestals, comprising recycled copolymer polypropylene (CPP) top plates, base plates, spacers, security locking keys, couplers and slope correctors, for use as support for decking and paving products for flat roofs, balconies, terraces, porches and exterior industrial surfaces. The product is designed for pedestrian use only and must not support moving and/or vibratory machinery or similar equipment.

(1) Hereinafter referred to as 'Certificate'.

The assessment includes

Product factors:

- compliance with Building Regulations
- compliance with additional regulatory or non-regulatory information where applicable
- evaluation against technical specifications
- assessment criteria and technical investigations
- uses and design considerations

Process factors:

- compliance with Scheme requirements
- installation, delivery, handling and storage
- production and quality controls
- maintenance and repair

Ongoing contractual Scheme elements†:

- regular assessment of production
- formal 3-yearly review



KEY FACTORS ASSESSED

- Section 1. Mechanical resistance and stability
- Section 2. Safety in case of fire
- Section 3. Hygiene, health and the environment
- Section 4. Safety and accessibility in use
- Section 5. Protection against noise
- Section 6. Energy economy and heat retention
- Section 7. Sustainable use of natural resources
- Section 8. Durability

The BBA has awarded this Certificate to the company named above for the product described herein. This product has been assessed by the BBA as being fit for its intended use provided it is installed, used and maintained as set out in this Certificate.

On behalf of the British Board of Agrément

Date of issue: 28 October 2024

Hardy Giesler
Chief Executive Officer

This BBA Agrément Certificate is issued under the BBA's Inspection Body accreditation to ISO/IEC 17020. Sections marked with † are not issued under accreditation.

The BBA is a UKAS accredited Inspection Body (No. 4345), Certification Body (No. 0113) and Testing Laboratory (No. 0357).

Readers MUST check that this is the latest issue of this Agrément Certificate by either referring to the BBA website or contacting the BBA directly.

The Certificate should be read in full as it may be misleading to read clauses in isolation.

Any photographs are for illustrative purposes only, do not constitute advice and should not be relied upon.

British Board of Agrément

1st Floor, Building 3, Hatters Lane
Croxley Park, Watford
Herts WD18 8YG

©2024

tel: 01923 665300
clientservices@bbacerts.co.uk
www.bbacerts.co.uk

SUMMARY OF ASSESSMENT AND COMPLIANCE

This section provides a summary of the assessment conclusions; readers should refer to the later sections of this Certificate for information about the assessments carried out.

Compliance with Regulations

Having assessed the key factors, the opinion of the BBA is that DPH pedestals, if installed, used and maintained in accordance with this Certificate, can satisfy or contribute to satisfying the relevant requirements of the following Building Regulations:



The Building Regulations 2010 (England and Wales) (as amended)

Requirement:	A1	Loading
Comment:		The product is acceptable. See section 1 of this Certificate.
Requirement:	B4(2)	External fire spread
Comment:		Roofs incorporating the product may be restricted by this Requirement. See section 2 of this Certificate.
Regulation:	7(1)	Materials and workmanship
Comment:		The product is acceptable. See sections 8 and 9 of this Certificate.
Regulation:	7(2)	Materials and workmanship
Comment:		The product is restricted by this Regulation. See section 2 of this Certificate.



The Building (Scotland) Regulations 2004 (as amended)

Regulation:	8(1)	Fitness and durability of materials and workmanship
Comment:		The product is acceptable. See sections 8 and 9 of this Certificate.
Regulation:	8(3)	Fitness and durability of materials and workmanship
Comment:		The product is restricted by this Regulation. See section 2 of this Certificate.
Regulation:	9	Building standards - construction
Standard:	1.1(a)(b)	Structure
Comment:		The product is acceptable, with reference to clauses 1.1.1 ⁽¹⁾⁽²⁾ and 1.1.2 ⁽¹⁾⁽²⁾ . See section 1 of this Certificate.
Standard:	2.7	Spread on external walls
Comment:		The product is restricted by this Standard, with reference to clause 2.7.2 ⁽¹⁾⁽²⁾ . See section 2 of this Certificate.
Standard:	2.8	Spread from neighbouring buildings
Comment:		Roofs incorporating the product may be restricted by this Standard, with reference to clause 2.8.1 ⁽¹⁾⁽²⁾ . See section 2 of this Certificate.
Standard:	7.1(a)	Statement of sustainability
Comment:		The product can contribute to satisfying the relevant Requirements of Regulation 9, Standards 1 to 6, and therefore will contribute to a construction meeting a bronze level of sustainability as defined in this Standard.
Regulation:	12	Building standards – conversion
Comment:		All comments given for the product under Regulation 9, Standards 1 to 6, also apply to this Regulation, with reference to clause 0.12.1 ⁽¹⁾⁽²⁾ and Schedule 6 ⁽¹⁾⁽²⁾ .

(1) Technical Handbook (Domestic).

(2) Technical Handbook (Non-Domestic).



The Building Regulations (Northern Ireland) 2012 (as amended)

Regulation:	23(1)(a)(i)	Fitness of materials and workmanship
Comment:	(iii)(b)(i)	The product is acceptable. See sections 8 and 9 of this Certificate.
Regulation:	23(2)	Fitness of materials and workmanship
Comment:		The product is restricted by this Regulation. See section 2 of this Certificate.
Regulation:	30	Stability
Comment:		The product is acceptable. See section 1 of this Certificate.
Regulation:	36(b)	External fire spread
Comment:		Roofs incorporating the product may be restricted by this Regulation. See section 2 of this Certificate.

Additional Information

NHBC Standards 2024

In the opinion of the BBA, DPH Pedestals, if installed, used and maintained in accordance with this Certificate, can satisfy or contribute to satisfying the relevant requirements in relation to *NHBC Standards*, Chapter 7.1 *Flat roofs, terraces and balconies*.

Fulfilment of Requirements

The BBA has judged DPH Pedestals to be satisfactory for use as described in this Certificate. The product has been assessed as support for decking and paving products for flat roofs, balconies, terraces, porches and exterior industrial surfaces. The product is designed for pedestrian use only and must not support moving and/or vibratory machinery or similar equipment.

ASSESSMENT

Product description and intended use

The Certificate holder provided the following description for the product under assessment. DPH Pedestals (see Figures 1 and 2) comprise recycled copolymer polypropylene (CPP) and consists of:

- top plate — screwed directly onto the base plate or the couplers. The top plate has a diameter of 145, 150, 155 and 170 mm and a minimum wall thickness of 4 mm. It can be fitted with various components to support complex shaped tiles and different applications such as stone pavers and timber decking
- couplers — used when the height of the pedestal exceeds 175 mm. The couplers have a minimum wall thickness of 4 mm. Locking keys on either side allow for mechanical bracing, providing enhanced stability when the height of the pedestals exceeds 600 mm
- base plate — with a minimum wall thickness of 4 mm, positioned or fixed to any substrate. The base plate has 8 fixing holes for screws or bolts. The top plate, adjustment ring and base plate have a safety feature, to prevent the top plate or sleeve from unscrewing. The base diameter is 170, 197 or 200 mm depending on the type of pedestal
- locking keys — to lock the pedestal at the required height. The Certificate holder states that the locking key has the function of blocking the post against involuntary unscrewing. Once the key is in place and the deck is mounted, the key can no longer be accessed and removed without disassembling the deck. Even if a key is lost, this has no effect on the durability and function of the post
- slope correctors — (0 to 5%) built into the head of DPH-02-PH5 to DPH-13-PH5 Pedestals and allows precise adjustment in increments of 0.5% if required. For some of the pedestals, it is integrated into the pedestal assembly, and for the remaining types, it can be fixed at the top of pedestal.

Figure 1 DPH Pedestals Exploded

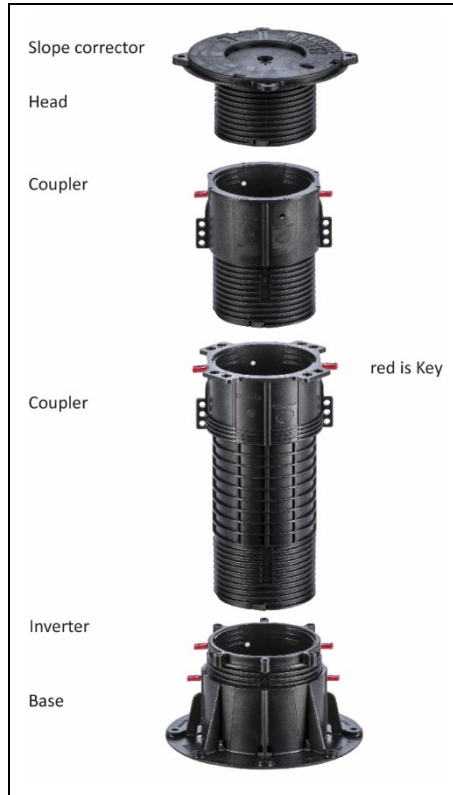

The product has the nominal characteristics given in Table 1.

Table 1 Nominal characteristics and components of DPH Pedestals

Pedestal ID	Pedestal type	Characteristic (unit)			
		Height (mm)	Top plate, ϕ (mm)	Base plate, ϕ (mm)	Components
DPH-F17	Fixed	17	145	170	—
DPH-F28	Fixed	28	145	170	—
DPH-1	Adjustable	18 - 28	170	197	DPH top plate DPH base plate
DPH-02	Adjustable	25 - 36	150	200	DPH top plate DPH base plate
DPH-02-PH5	Adjustable	33 - 44	155	200	DPH top plate DPH base plate Slope corrector
DPH-3	Adjustable	50 - 78	150	200	DPH top plate DPH base plate
DPH-3-PH5	Adjustable	55 - 79	155	200	DPH top plate DPH base plate Slope corrector
DPH-4-PH5	Adjustable	77 - 108	155	200	DPH top plate DPH base plate Slope corrector
DPH-5-PH5	Adjustable	100 - 175	155	200	DPH-5 PH5 Pedestal 4 locking keys Slope corrector
DPH-6-PH5	Adjustable	175 - 285	155	200	DPH-5-Ph5 NSC Pedestal 1 coupler DPH-C2 6 locking keys
DPH-7-PH5	Adjustable	285 - 400	155	200	DPH-5-Ph5 NSC Pedestal 1 coupler DPH-C5 6 locking keys
DPH-8-PH5	Adjustable	355 - 515	155	200	DPH-5-PH5 NSC Pedestal 1 coupler DPH-C2 1 coupler DPH-C5 8 locking keys
PH-9-PH5	Adjustable	465 - 625	155	200	DPH-5-PH5 NSC Pedestal 2 coupler DPH-C5 8 locking keys
DPH-10-PH5	Adjustable	545 - 740	155	200	DPH-5-PH5 NSC Pedestal 1 coupler DPH-C2 2 coupler DPH-C5 10 locking keys
DPH-11-PH5	Adjustable	645 - 850	155	200	DPH-5-PH5 NSC Pedestal 3 coupler DPH-C5 10 locking keys
DPH-12-PH5	Adjustable	720 - 960	155	200	DPH-5-PH5 NSC Pedestal 1 coupler DPH-C2 3 coupler DPH-C5 12 locking keys
DPH-13-PH5	Adjustable	830 - 1070	155	200	DPH-5-PH5 NSC Pedestal 4 coupler DPH-C5 12 locking keys

Figure 2 DPH Pedestals — illustrations

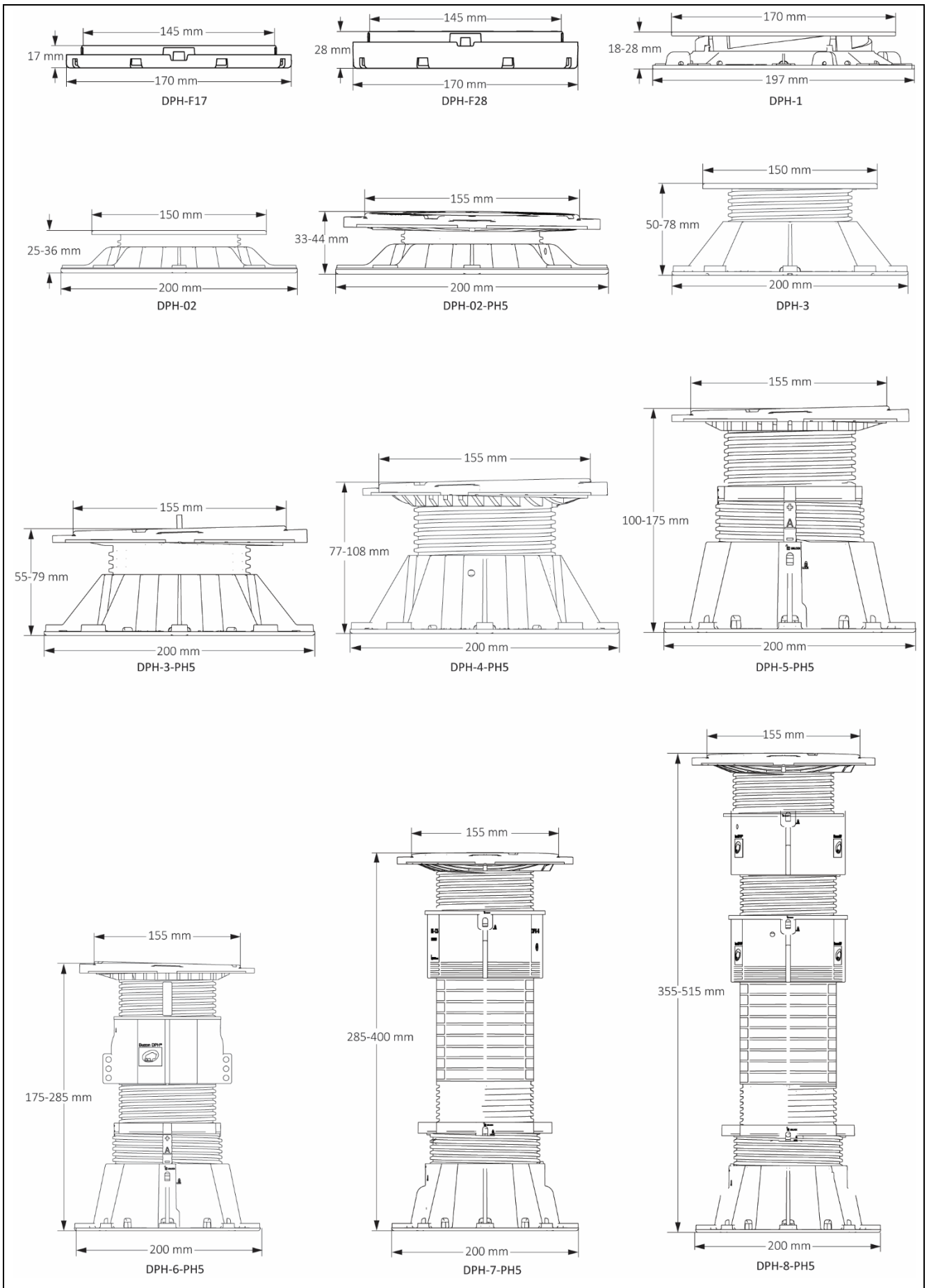

Figure 2 DPH Pedestals — illustrations (continued)

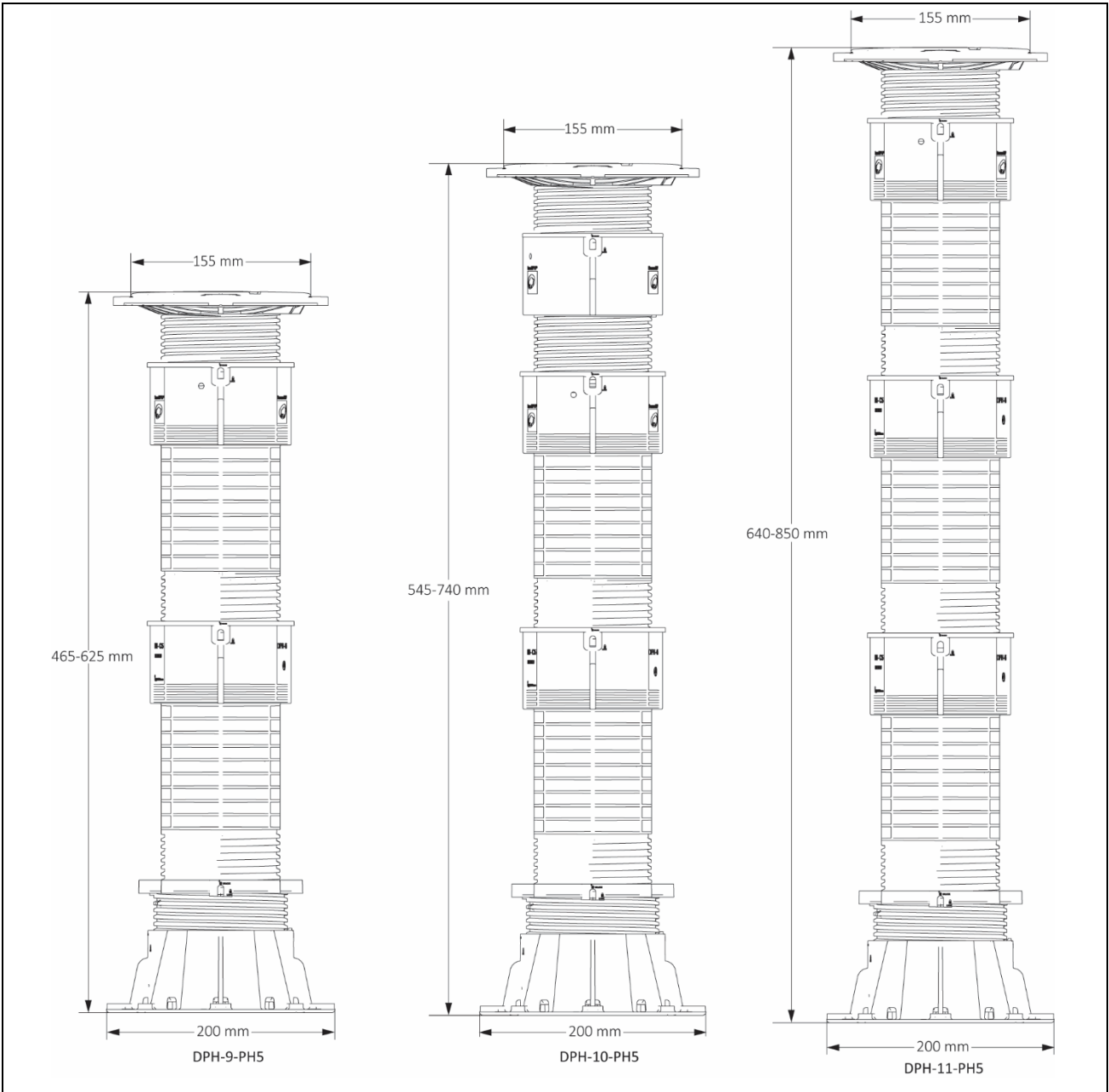
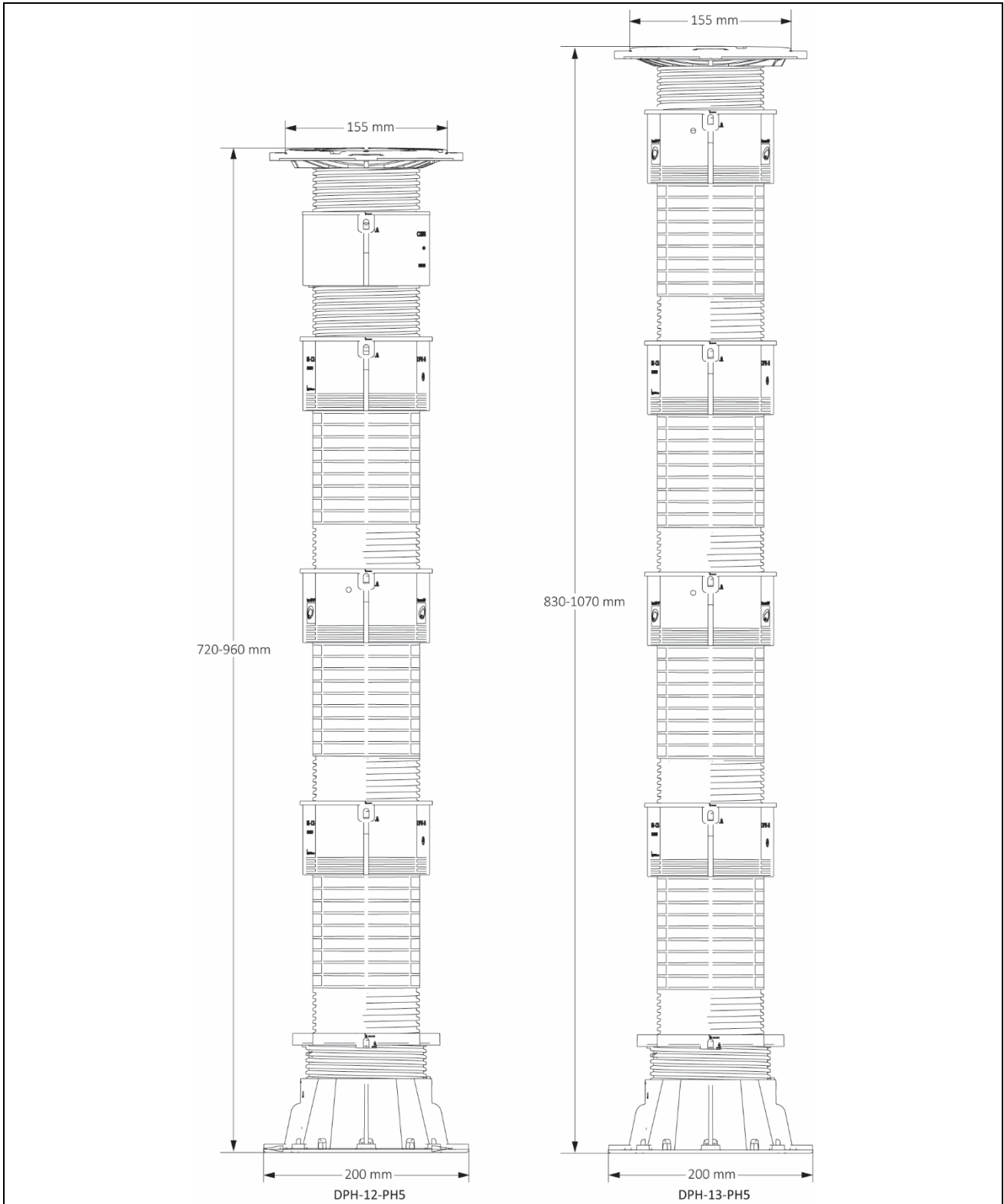

Figure 2 DPH Pedestals — illustrations (continued)



Ancillary Items

The Certificate holder recommends the following ancillary items for use with the product, but these materials have not been assessed by the BBA and are outside the scope of this Certificate:

- spacer tabs (see Figure 3) — available in thicknesses of 2, 3, 4.5, 6, 8 and 10 mm. Spacer tabs provide proper alignment of the pavers placed on top of the pedestals
- shims — to stabilise the paver, provide additional acoustic comfort and compensate for variations in paver thickness. Shims are 1 or 2 mm thick with maltase-cross shaped levellers and are available as U-E10 or U-E20 (see Figure 4)
- batten holder — firmly holds the joists supporting the deck boards. There are two types: fixed (maximum size of batten is 65 mm) and universal (maximum size of batten is up to 90 mm) (see Figure 5). The minimum thickness of the joist is 30 mm.

Figure 3 Spacer tabs

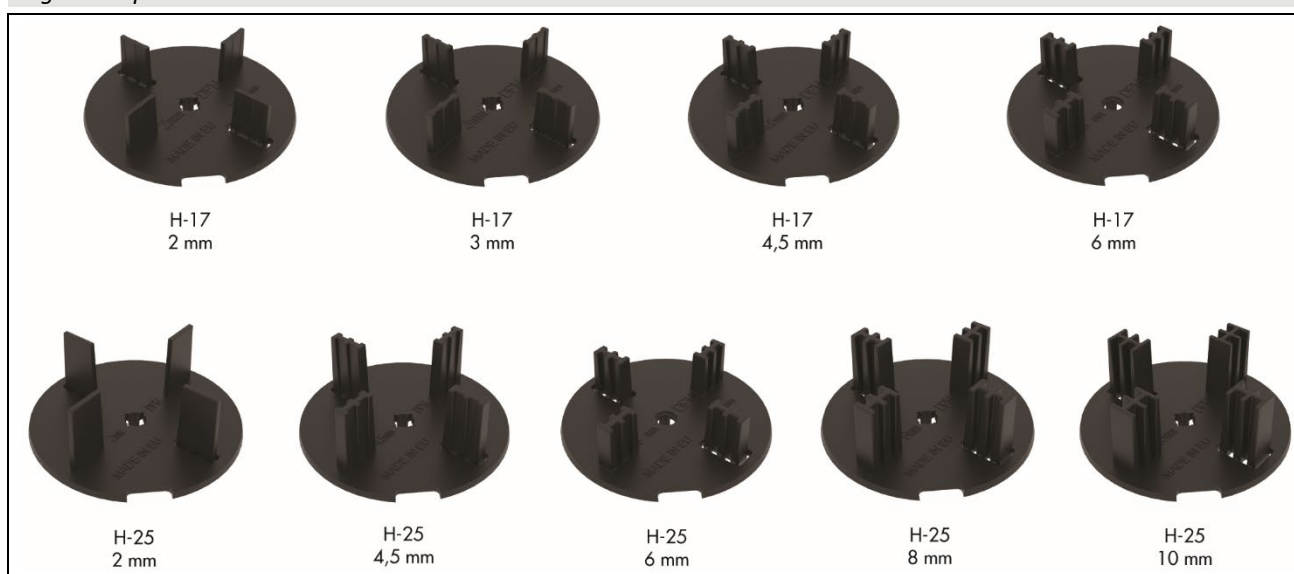

Figure 4 Shims

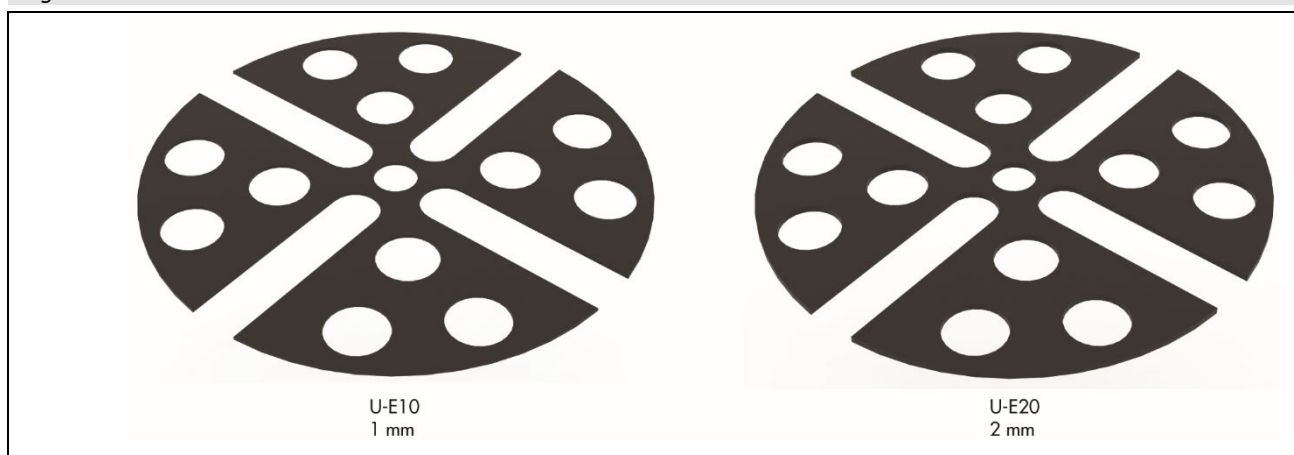
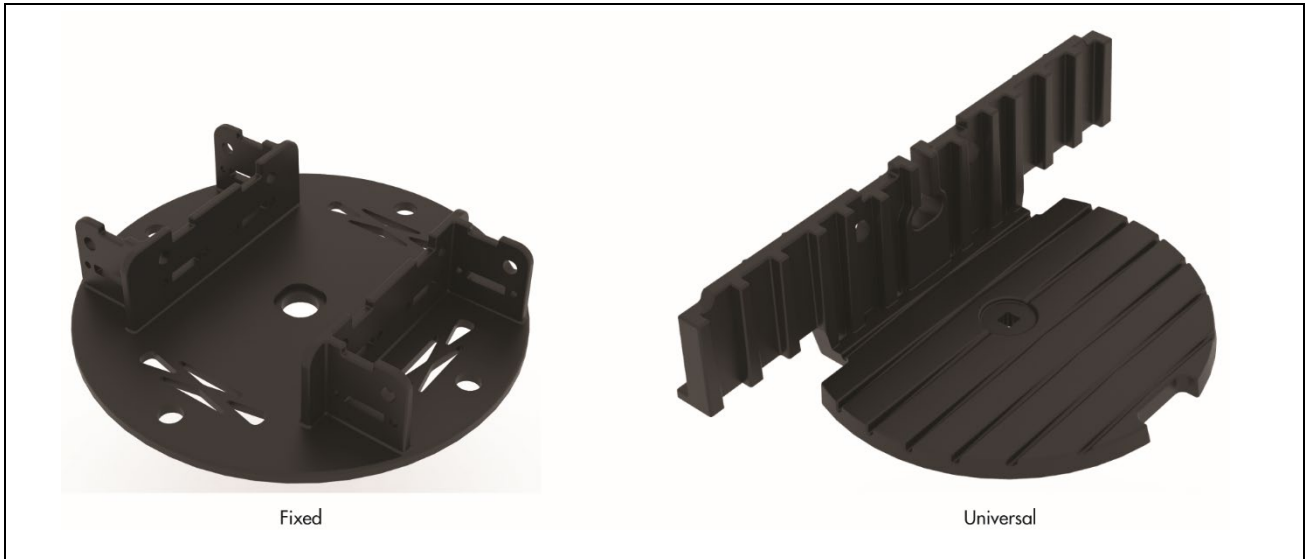

Figure 5 Batten holder



Definitions for products and applications inspected

The pedestals are designed for pedestrian use only. The pedestals are not designed to support moving/vibratory machines and equipment, including maintenance, cleaning or vehicular traffic.

Product assessment – key factors

The product was assessed for the following key factors, and the outcome of the assessment is shown below. Conclusions relating to the Building Regulations apply to the whole of the UK unless otherwise stated.

1 Mechanical resistance and stability

Data were assessed for the following characteristics.

1.1 Strength and stability

1.1.1 DPH Pedestals were subjected to short-term characteristic compressive loads based on the specifications to EN 12825 : 2001. The loads were applied on the whole surface area of the pedestal (1/1). The characteristic compressive failure loads are summarized in Table 2 of this Certificate.

Table 2 DPH Pedestals — short-term characteristic compressive failure load values

Product assessed	Assessment method	Tested height (mm)	Requirement	Result ⁽¹⁾
				Failure Load at 23°C (kN) Test (1/1)
DPH-F17	Based on the specifications to EN 12825 : 2001	17	Value achieved	60.29
DPH-F28		28		47.53
DPH-1		28		20.38
DPH-02		36		14.39
DPH-02-PH5		57		12.34
DPH-03		78		13.12
DPH-3-PH5		79		13.26
DPH-4-PH5		108		14.55
DPH-5-PH5		175		13.52
DPH-6-PH5		285		15.06
DPH-7-PH5		400		11.55
DPH-8-PH5		515		11.12
DPH-9-PH5		625		10.65
DPH-10-PH5	740	10.67		
DPH-11-PH5	850	9.65		
DPH-12-PH5	960	9.69		
DPH-13-PH5	1070	9.56		

(1) Maximum load per one pedestal not to exceed the value of 1/1.

1.1.2 On the basis of data assessed, the product has the compressive strength as stated in Table 2. The values in Table 2 must be divided by the Factor of Safety of 3 to find the design resistance of each pedestal.

1.2 Behaviour under loading

An evaluation of creep behaviour was assessed. The product is not deemed to deform non-uniformly due to creep behaviour.

2 Safety in case of fire

Data were assessed for the following characteristics.

2.1 External fire spread

2.1.1 When tested to DD CEN/TS 1187 : 2012, Test 4, the constructions given in Table 3 of this Certificate achieved a classification under BS EN 13501-5 : 2016 of B_{ROOF}(t4).

Table 3 External fire spread classifications

Product assessed			Assessment method	Reinforcement	Reaction to fire classification
Construction from base to top					
Supporting deck	Wood particle board	16 mm thickness 680 kg·m ⁻³ density	Tested to DD CEN/TS 1187 : 2012, Test 4 External fire spread classification to EN 13501-5 :2016 ⁽¹⁾⁽²⁾	—	—
Vapour barrier	Self-adhesive bituminous air and vapour control layer with a polyester-coated aluminium foil and glass fleece reinforcement and a mineral finish	2.5 mm thickness 3000 g·m ⁻² surface weight		200 g·m ⁻² polyester-coated aluminium foil and 60 g·m ⁻² glass fleece	E
Adhesive	PUR adhesive	75 g·m ⁻² applied amount with twin cartridge applicator gun		—	—
Insulation layer	Polyisocyanurate (PIR) insulation boards with an aluminium facing and backing	120 mm thickness 30 kg·m ⁻³ density facing aluminium 37 g·m ⁻² backing aluminium 37 g·m ⁻²		—	E
Roof covering – first layer	Self-adhesive elastomeric underlayer with a glass lattice reinforcement	3 mm thickness 3500 g·m ⁻² surface weight		200 g·m ⁻² glass lattice	—
Roof covering – top layer	Torched-on elastomeric underlayer with a spunbond polyester reinforcement and a charcoal mineral finish	5.2 mm thickness 6500 g·m ⁻² surface weight		250 g·m ⁻² spunbond polyester	—
Pedestal system	PB-3 (loosely placed on the top layer) consisting of PB top plate, base plate, spacer tabs 10 mm h17 and U-E20 SBR	90 mm height 170 mm top diameter 197 mm bottom diameter 492 g mass		—	B _{ROOF} (t4)
Ceramic tiles	Loosely laid onto the pedestals	20 mm thickness 417 x 417 mm and 835 x 417 mm 54000 g·m ⁻² surface weight		—	A1

(1) Fire test and classification reports, reference 20958A and 20958B respectively, conducted by Warringtonfire Gent. Reports are available from the Certificate holder.

(2) Fields of Application are included in the above reports:

Direct Field of Application:

- Range of roof pitches: ≤ 10°

- Deck: wood particle board (16 mm thick or more and 680 kg·m⁻³ density or more)

Extended Field of Application:

- Range of tiles: 20 mm thick or more, 10 mm or less joints, 54000 g·m⁻² surface weight and class A1 reaction to fire

- Range of pedestals can be 90 mm or more height.

2.1.2 On the basis of data assessed, when classified to BS EN 13501-5 : 2016, the construction incorporating the pedestals given in Table 3 of this Certificate, achieved external fire exposure resistance classification B_{ROOF}(t4) for slopes below or equal to 10° and so, with the exceptions given in sections 2.2.2 to 2.2.4, is unrestricted in terms of proximity to a relevant boundary by the documents supporting the national Building Regulations. Restrictions may apply at junctions with compartment walls.

2.1.3 The classification and permissible areas of use of other specifications must be confirmed by reference to the requirements of the documents supporting the national Building Regulations.

2.2 Reaction to fire

2.2.1 The Certificate holder has not declared a reaction to fire classification for the product in accordance with BS EN 13501-1 : 2018.

2.2.2 On the basis of data assessed, in Scotland, the product must not be used on balconies on buildings with a storey 11 m or more above the ground.

2.2.3 On the basis of data assessed, in England and Wales, the product must not be used on balconies on buildings that have a storey at least 18 m above ground level and which contain one or more dwellings, an institution, a room for residential purposes (excluding, in Wales only, any room in a hostel, hotel or boarding house), student accommodation, care homes, sheltered housing, hospitals or dormitories in boarding schools. Additionally, in England, the product must not be used on balconies of residential buildings with a storey 11 m or more in height.

2.2.4 On the basis of the data assessed, in Northern Ireland, the product must not be used on balconies on buildings that have a storey at least 18 m above ground level and which contain one or more dwellings, an institution, a room for residential purposes (excluding any room in a hostel, hotel or boarding house), student accommodation, care homes, nursing homes, sheltered housing, hospitals, dormitories in boarding schools and places of lawful detention.

3 Hygiene, health and the environment

Data were assessed for the following characteristics.

3.1 Resistance to chemicals

3.1.1 The material representative samples were stored in accordance with ASTM D 543-14 and were subjected to tensile tests in accordance with DIN EN ISO 527-1 : 2012-06, the changes in volume, mass and dimensions were also measured. The density was measured in accordance with DIN EN ISO 1182 : 2013-04. Results are given in Tables 4 and 5 of this Certificate.

Table 4 Tensile properties

Material assessed	Assessment method	Requirement	Result ⁽¹⁾
Recycled copolymer polypropylene (CPP)	DIN EN ISO 527-1 : 2012-06 Control sample	Value achieved	Tensile modulus 2040 ± 25 MPa
			Tensile stress 18.9 ± 0.7 MPa
			Elongation at break 18.5 ± 5.8 (%)
	DIN EN ISO 527-1 : 2012-06 (7 days at 50°C in 3% Sulfuric acid)	Value achieved	Tensile modulus 1970 ± 31 MPa
			Tensile stress 18.9 ± 0.7 MPa
			Elongation at break 20.3 ± 6.7 (%)
	DIN EN ISO 527-1 : 2012-06 (7 days at 50°C in 10% Sodium Chloride)	Value achieved	Tensile modulus 1960 ± 23 MPa
			Tensile stress 19.3 ± 0.5 MPa
			Elongation at break 18.9 ± 5.3 (%)
	DIN EN ISO 527-1 : 2012-06 (7 days at 50°C in 5% Sodium Hypochlorite)	Value achieved	Tensile modulus 1920 ± 19 MPa
			Tensile stress 19.4 ± 0.4 MPa
			Elongation at break 14.1 ± 2.5 (%)

(1) Mean values ± standard deviation

Table 5 Dimensional stability

Material assessed	Assessment method ⁽¹⁾	Requirement	Result (%) ⁽¹⁾
Recycled copolymer polypropylene (CPP)	ASTM D543-14 (7 days at 50°C in 3% Sulfuric acid)	Value achieved	Thickness -0.04 ± 0.07
			Width 0.13 ± 0.16
			Weight change 0.24 ± 0.09
			Volume change 0.25 ± 0.15
Recycled copolymer polypropylene (CPP)	ASTM D543-14 (7 days at 50°C in 10% Sodium Chloride)	Value achieved	Thickness -0.27 ± 0.38
			Width 0.1 ± 0.1
			Weight change 0.21 ± 0.31
			Volume change 0.19 ± 0.41
Recycled copolymer polypropylene (CPP)	ASTM D543-14 (7 days at 50°C in 5% Sodium Hypochlorite)	Value achieved	Thickness -0.12 ± 0.31
			Width 0.07 ± 0.15
			Weight change 0.23 ± 0.16
			Volume change 0.27 ± 0.15

(1) Mean values ± standard deviation

3.1.2 On the basis of data assessed, all tested chemicals caused only minor variation in dimension, weight and volume. Storage in all chemicals caused no changes in appearance visible to the naked eye.

4 Safety and accessibility in use

Not applicable.

5 Protection against noise

Not applicable.

6 Energy economy and heat retention

Not applicable.

7 Sustainable use of natural resources

7.1 Reuse and recyclability

The product is manufactured from CPP, which can be recycled.

8 Durability

8.1 The potential mechanisms for degradation and the known performance characteristics of the materials in the product were assessed.

8.2 Service life

Under normal service conditions, the product will have a life in excess of 30 years, provided it is designed, installed and maintained in accordance with this Certificate and the Certificate holder's instructions.

PROCESS ASSESSMENT

Information provided by the Certificate holder was assessed for the following factors:

9 Design, installation, workmanship and maintenance

9.1 Design

9.1.1 The design process was assessed by the BBA and the following requirements apply in order to satisfy the performance specified in this Certificate.

9.1.2 Designers, planners, contractors and/or installers must ensure that the installation of DPH Pedestals is in accordance with the Certificate holder's instructions and the information given in this Certificate.

9.1.3 The suitability of the floor/deck to support the loads and the expected displacement in both the short- and long-term must be considered by a suitably experienced and competent individual.

9.1.4 It is a responsibility of the designer to ensure that the pedestals are not cut in any situation.

9.1.5 A suitably experienced and competent individual must undertake the calculations to the relevant code of practice, including:

- the characteristic values of the imposed loads for flat roofs, balconies, terraces and porches in accordance with BS EN 1991-1-1 : 2002 and its UK National Annex, and the characteristic values of the imposed loads for areas of industrial use in accordance with PD 6688-1-1 : 2011
- the characteristic values of the self-weight and finishes for floors, roofs, balconies in accordance with BS EN 1991-1-1 : 2002 and its UK National Annex
- the ultimate load applied on each pedestal in accordance with either equation 6.10 or less favourable equations 6.10a and 6.10b of BS EN 1990 : 2023 and its UK National Annex based on self-weight of the floor and finishes, and imposed loads as defined in first and second bullet points mentioned above

- take into account the short- and long-term displacement of each pedestal mentioned in Table 1 of this Certificate. Also, take into account the short- and long-term deflection of substrates
- an assessment of the robustness of the design to ensure if any locking key, positioned at one corner of a slab, inadvertently was unlocked due to foreseen or unforeseen events (incorrect installation, impact, or survival after an accidental event) to prevent collapse of the floor or roof or balcony.

9.2 Installation

9.2.1 Installation instructions provided by the Certificate holder were assessed and judged to be appropriate and adequate.

9.2.2 Installation must be carried out in accordance with this Certificate and the Certificate holder's instructions. A summary of instructions and guidance is provided in Annex A of this Certificate.

9.2.3 DPH Pedestals must be transported in their original packaging. It must be ensured that no damage occurs during transport, and the pedestal components must be checked before installation. The pedestals must be handled with care during installation, to avoid damage by being dropped.

9.3 Workmanship

Practicability of installation was assessed by the BBA on the basis of the Certificate holder's information and a site visit to witness an installation in progress. To achieve the performance described in this Certificate, installation of the product must be carried out by a competent general builder, or a contractor experienced with this type of product.

9.4 Maintenance and repair

9.4.1 As the product is confined within the floor void and has suitable durability. Maintenance is not required.

The following requirements apply in order to satisfy the performance assessed in this Certificate:

9.4.2 The pedestals are manufactured from CPP and do not require maintenance in general.

9.4.3 If the pedestals need to be replaced, the guidelines provided in the Certificate holder's manual must be followed.

10 Manufacture

10.1 The production processes for the product have been assessed, and provide assurance that the quality controls are satisfactory according to the following factors:

10.1.1 The manufacturer has provided documented information on the materials, processes, testing and control factors.

10.1.2 The quality control operated over batches of incoming materials has been assessed and deemed appropriate and adequate.

10.1.3 The quality control procedures and product testing to be undertaken have been assessed and deemed appropriate and adequate.

10.1.4 The process for management of non-conformities has been assessed and deemed appropriate and adequate.

10.1.5 An audit of each production location was undertaken, and it was confirmed that the production process was in accordance with the documented process, and that equipment has been properly tested and calibrated.

† 10.2 The BBA has undertaken to review the above measures on a regular basis through a surveillance process, to verify that the specifications and quality control operated by the manufacturer are being maintained.

11 Delivery and site handling

11.1 The Certificate holder stated that the product is delivered to site in packaging bearing the details of components including type and dimensions, and the BBA logo incorporating the number of this Certificate.

Supporting information in this Annex is relevant to the product but has not formed part of the material assessed for the Certificate.

Construction (Design and Management) Regulations 2015

Construction (Design and Management) Regulations (Northern Ireland) 2016

Information in this Certificate may assist the client, designer (including Principal Designer) and contractor (including Principal Contractor) to address their obligations under these Regulations.

Management Systems Certification for production

The management system of the manufacturer has been assessed and registered as meeting the requirements of BS EN ISO 9001 : 2015 by SGS (Certificate BE 18/819943236)

Additional information on installation

A.1 Good site practice must be observed to prevent damage to the components of the pedestal.

A.2 DPH Pedestals can be installed on a wide range of solid, even and stable substrates, such as concrete slabs, cement screeds, waterproof membranes and insulation panels. Substrates must be free of dust, dirt and waste material. Use of wedges under pedestals must be avoided. The designer must confirm layout, position and height of the decking or pavers. Installation must be strictly in accordance with the Certificate's holder's Installation Manual.

A.3 For installation, mason wire is used to set out the first line, and a second line, perpendicular to the first. Chalk can be used to draw lines on the substrate. After setting out the initial two lines, grid lines can be extended to mark the location of the pedestals. The dimensions of grid lines depend on the dimensions of the paver used. Further guidelines may be found in the Certificate holder's Installation Manual.

A.4 Three pedestals need to be placed at the junction of the two initially drawn lines, and checked with a leveller to ensure the heads of the pedestals are at the same height and level (see Figure 6.1). If necessary, accessories such as spacer tabs or shims can be used, such as to compensate for the variation in paver thickness. The paver is then balanced and levelled on the three pedestals (see Figure 6.2).

A.5 A fourth pedestal can then be inserted (see Figure 6.3) and its head level checked. The pedestal's head and paver must be perfectly level.

Figure 6 Pedestal installation

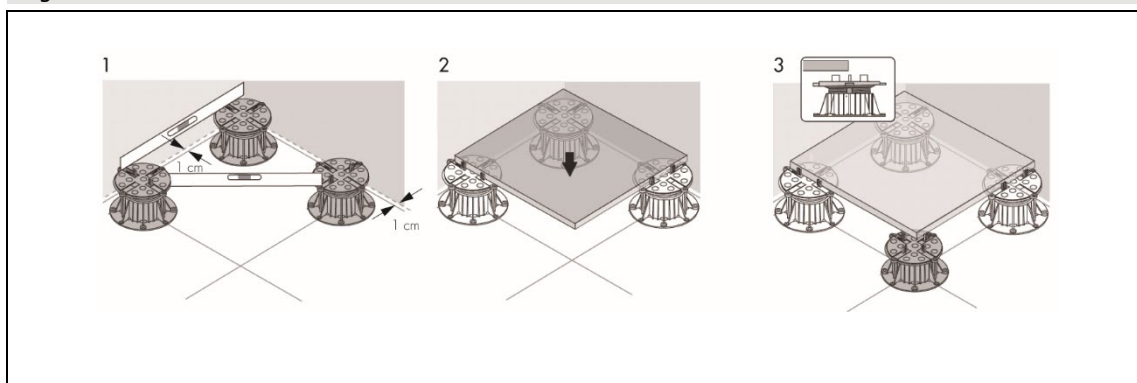

A.6 With the first paver installed, the next pedestal must be placed (in line with the first paver). The level is checked for the two most recently placed pedestals under the first paver, and the newly placed pedestal (as shown in Figure 7). The second paver is then balanced on the three checked pedestals, with the information in sections A.5 and A.6 followed regarding levelling and the placement of the fourth pedestal. In the same manner, all pavers are placed along the wall, ensuring all pavers are level. If pavers are not level, accessories mentioned in the *Product description and intended use* section of this Certificate may be used.

Figure 7 Pedestal installation cont.

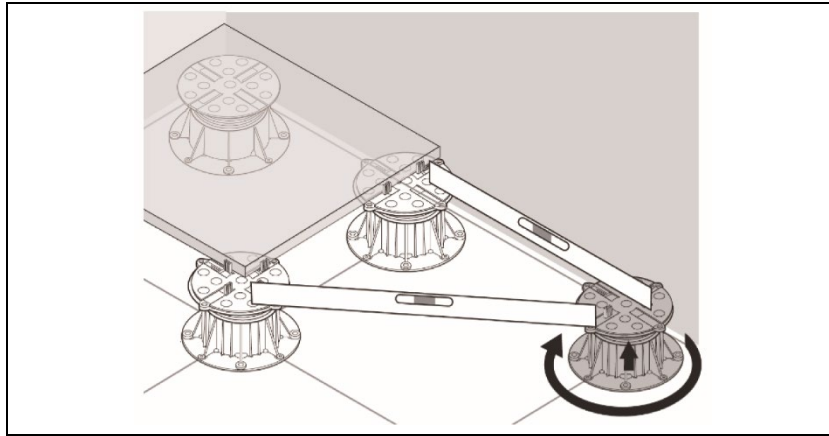

A.7 With the completion of the first row of pavers, another row, perpendicular to the first row, must be executed in the same manner as described previously. Further details can be found in the Certificate holder's Installation Manual.

A.8 If the design demands a slope, the slope corrector can be fixed on the pedestal for DPH-2 and DPH-3 subcategories. For the other pedestals, the slope corrector is integrated into the product. The direction of the slope is marked on the floor with chalk. Spacer tabs and shims can be used with the product if needed. Further details can be requested from the Certificate holder.

A.9 Typically, four pedestals placed at the edges are used to support each paver. If needed, one extra pedestal in the middle of the paver may be used for improved stability. In the case of large pavers, it is recommended to use the extra pedestal. Installation must be in accordance with the installation manual from the paver manufacturer.

A.10 If wood is used for the system, then batten holders must be used. The type of batten holder will depend on the dimension of wood joist or batten used. Wood joists or battens placed on pedestals must be fixed with screws.

A.11 After installation of each paver, the alignment must be checked.

A.12 Installation must be in accordance with the Certificate holder's instructions and this Certificate.

Bibliography

ASTM D 543-14 *Standard Practices For Evaluation The Resistance Of Plastics To Chemical Reagents*

BS EN 1990 : 2023 *Eurocode — Basis of structural and geotechnical design*

UK to BS EN 1990 : 2023 UK National Annex to *Eurocode — Basis of structural and geotechnical design*

BS EN 1991-1-1 : 2002 *Eurocode 1 — Actions on structures — General actions — Densities, self-weight, imposed loads for buildings*

NA to BS EN 1991-1-1 : 2002 UK National Annex to *Eurocode 1 — Actions on structures — General actions — Densities, self-weight, imposed loads for buildings*

BS EN 13501-1 : 2007 *Fire classification of construction products and building elements — Classification using data from reaction to fire tests*

BS EN 13501-5 : 2016 *Fire classification of construction products and building elements — Classification using data from external fire exposure to roofs tests*

BS EN ISO 9001 : 2015 *Quality management systems — Requirements*

DIN EN ISO 527-1 : 2012-06 *Plastics — Determination of tensile properties — General principles*

DIN EN ISO 1182 : 2013-04 *Reaction to fire tests for products — Non-combustibility test*

DD CEN/TS 1187 : 2012 *Test methods for external fire exposure to roofs*

EN 12825 : 2001 *Raised access floors*

PD 6688-1-1 : 2011 *Recommendations for the design of structures to BS EN 1991-1-1*

Conditions

1 This Certificate:

- relates only to the product that is named and described on the front page
- is issued only to the company, firm, organisation or person named on the front page – no other company, firm, organisation or person may hold or claim that this Certificate has been issued to them
- has to be read, considered and used as a whole document – it may be misleading and will be incomplete to be selective
- is copyright of the BBA
- and any matter arising out of or in connection with it or its subject matter (including non-contractual disputes or claims) is governed by and construed in accordance with the law of England and Wales.
- the courts of England and Wales shall have exclusive jurisdiction to settle any matter arising out of or in connection with this Certificate or its subject matter (including non-contractual disputes or claims).

2 Publications, documents, specifications, legislation, regulations, standards and the like referenced in this Certificate are those that were current and/or deemed relevant by the BBA at the date of issue or reissue of this Certificate.

3 This Certificate will be displayed on the BBA website, and the Certificate Holder is entitled to use the Certificate and Certificate logo, provided that the product and its manufacture and/or fabrication, including all related and relevant parts and processes thereof:

- are maintained at or above the levels which have been assessed and found to be satisfactory by the BBA
- continue to be checked as and when deemed appropriate by the BBA under arrangements that it will determine
- are reviewed by the BBA as and when it considers appropriate.

4 The BBA has used due skill, care and diligence in preparing this Certificate, but no warranty is provided.

5 In issuing this Certificate the BBA is not responsible and is excluded from any liability to any company, firm, organisation or person, for any matters arising directly or indirectly from:

- the presence or absence of any patent, intellectual property or similar rights subsisting in the product or any other product
- the right of the Certificate holder to manufacture, supply, install, maintain or market the product
- actual installations of the product, including their nature, design, methods, performance, workmanship and maintenance
- any works and constructions in which the product is installed, including their nature, design, methods, performance, workmanship and maintenance
- any loss or damage, including personal injury, howsoever caused by the product, including its manufacture, supply, installation, use, maintenance and removal
- any claims by the manufacturer relating to UKCA marking and CE marking.

6 Any information relating to the manufacture, supply, installation, use, maintenance and removal of this product which is contained or referred to in this Certificate is the minimum required to be met when the product is manufactured, supplied, installed, used, maintained and removed. It does not purport in any way to restate the requirements of the Health and Safety at Work etc. Act 1974, or of any other statutory, common law or other duty which may exist at the date of issue or reissue of this Certificate; nor is conformity with such information to be taken as satisfying the requirements of the 1974 Act or of any statutory, common law or other duty of care.

Buzon Pedestal International

4eme Avenue 25
Herstal 4040
Belgium

Tel: +32 42483983

e-mail: info@buzon-world.com

website: www.buzon-world.com



Agrément Certificate

24/7282

Product Sheet 3 Issue 1

BUZON PEDESTALS

BC PEDESTALS

This Agrément Certificate Product Sheet⁽¹⁾ relates to BC Pedestals, comprising recycled copolymer polypropylene (CPP) top plates, base plates, spacers, security locking keys, couplers and slope correctors, for use as support for decking and paving products for flat roofs, balconies, terraces, porches and exterior industrial surfaces. The product is designed for pedestrian use only and must not support moving and/or vibratory machinery or similar equipment.

(1) Hereinafter referred to as 'Certificate'.

The assessment includes

Product factors:

- compliance with Building Regulations
- compliance with additional regulatory or non-regulatory information where applicable
- evaluation against technical specifications
- assessment criteria and technical investigations
- uses and design considerations

Process factors:

- compliance with Scheme requirements
- installation, delivery, handling and storage
- production and quality controls
- maintenance and repair

Ongoing contractual Scheme elements†:

- regular assessment of production
- formal 3-yearly review



KEY FACTORS ASSESSED

- Section 1. Mechanical resistance and stability
- Section 2. Safety in case of fire
- Section 3. Hygiene, health and the environment
- Section 4. Safety and accessibility in use
- Section 5. Protection against noise
- Section 6. Energy economy and heat retention
- Section 7. Sustainable use of natural resources
- Section 8. Durability

The BBA has awarded this Certificate to the company named above for the product described herein. This product has been assessed by the BBA as being fit for its intended use provided it is installed, used and maintained as set out in this Certificate.

On behalf of the British Board of Agrément

Date of issue: 28 October 2024

Hardy Giesler
Chief Executive Officer

This BBA Agrément Certificate is issued under the BBA's Inspection Body accreditation to ISO/IEC 17020. Sections marked with † are not issued under accreditation.

The BBA is a UKAS accredited Inspection Body (No. 4345), Certification Body (No. 0113) and Testing Laboratory (No. 0357).

Readers MUST check that this is the latest issue of this Agrément Certificate by either referring to the BBA website or contacting the BBA directly.

The Certificate should be read in full as it may be misleading to read clauses in isolation.

Any photographs are for illustrative purposes only, do not constitute advice and should not be relied upon.

British Board of Agrément

1st Floor, Building 3, Hatters Lane
Croxley Park, Watford
Herts WD18 8YG

©2024

tel: 01923 665300
clientservices@bbacerts.co.uk
www.bbacerts.co.uk

SUMMARY OF ASSESSMENT AND COMPLIANCE

This section provides a summary of the assessment conclusions; readers should refer to the later sections of this Certificate for information about the assessments carried out.

Compliance with Regulations

Having assessed the key factors, the opinion of the BBA is that BC Pedestals, if installed, used and maintained in accordance with this Certificate, can satisfy or contribute to satisfying the relevant requirements of the following Building Regulations:



The Building Regulations 2010 (England and Wales) (as amended)

Requirement:	A1	Loading
Comment:		The product is acceptable. See section 1 of this Certificate.
Requirement:	B4(2)	External fire spread
Comment:		Roofs incorporating the product may be restricted by this Requirement. See section 2 of this Certificate.
Regulation:	7(1)	Materials and workmanship
Comment:		The product is acceptable. See sections 8 and 9 of this Certificate.
Regulation:	7(2)	Materials and workmanship
Comment:		The product is restricted by this Regulation. See section 2 of this Certificate.



The Building (Scotland) Regulations 2004 (as amended)

Regulation:	8(1)	Fitness and durability of materials and workmanship
Comment:		The product is acceptable. See sections 8 and 9 of this Certificate.
Regulation:	8(3)	Fitness and durability of materials and workmanship
Comment:		The product is restricted by this Regulation. See section 2 of this Certificate.
Regulation:	9	Building standards - construction
Standard:	1.1(a)(b)	Structure
Comment:		The product is acceptable, with reference to clauses 1.1.1 ⁽¹⁾⁽²⁾ and 1.1.2 ⁽¹⁾⁽²⁾ of this Standard. See section 1 of this Certificate.
Standard:	2.7	Spread on external walls
Comment:		The product is restricted by this Standard, with reference to clause 2.7.2 ⁽¹⁾⁽²⁾ . See section 2 of this Certificate.
Standard:	2.8	Spread from neighbouring buildings
Comment:		Roofs incorporating the product may be restricted by this Standard, with reference to clause 2.8.1 ⁽¹⁾⁽²⁾ . See section 2 of this Certificate.
Standard:	7.1(a)	Statement of sustainability
Comment:		The product can contribute to satisfying the relevant Requirements of Regulation 9, Standards 1 to 6, and therefore will contribute to a construction meeting a bronze level of sustainability as defined in this Standard.
Regulation:	12	Building standards - conversion
Comment:		All comments given for the product under Regulation 9, Standards 1 to 6, also apply to this Regulation, with reference to clause 0.12.1 ⁽¹⁾⁽²⁾ and Schedule 6 ⁽¹⁾⁽²⁾ .

(1) Technical Handbook (Domestic).

(2) Technical Handbook (Non-Domestic).



The Building Regulations (Northern Ireland) 2012 (as amended)

Regulation:	23(1)(a)(i)	Fitness of materials and workmanship
Comment:	(iii)(b)(i)	The product is acceptable. See sections 8 and 9 of this Certificate.
Regulation:	23(2)	Fitness of materials and workmanship
Comment:		The product is restricted by this Regulation. See section 2 of this Certificate.
Regulation:	30	Stability
Comment:		The product is acceptable. See section 1 of this Certificate.
Regulation:	36(b)	External fire spread
Comment:		Roofs incorporating the product may be restricted by this Regulation. See section 2 of this Certificate.

Additional Information

NHBC Standards 2024

In the opinion of the BBA, BC Pedestals, if installed, used and maintained in accordance with this Certificate, can satisfy or contribute to satisfying the relevant requirements in relation to *NHBC Standards*, Chapter 7.1 *Flat roofs, terraces and balconies*.

Fulfilment of Requirements

The BBA has judged BC Pedestals to be satisfactory for use as described in this Certificate. The product has been assessed as to provide support for decking and paving products for flat roofs, balconies, terraces, porches and exterior industrial surfaces. This product is designed for pedestrian use only and must not support moving and/or vibratory machinery or similar equipment.

ASSESSMENT

Product description and intended use

The Certificate holder provided the following description for the product under assessment. BC Pedestals (see figure 1) comprise recycled copolymer polypropylene (CPP) and consists of:

- top plates — screwed directly onto the base plate or onto the couplers. The top plate has a diameter of 145, and a minimum wall thickness of 4 mm. It can be fitted with various components to support complex shaped tiles and different applications such as stone pavers and timber decking
- couplers — used when the height of the pedestal exceeds 215 mm and have a minimum wall thickness of 4 mm. Two wire hooks on the sides allow for the pedestals to be tied to each other, providing greater stability
- inverter — the inverter is a type of coupler that allows for precise height adjustment including after tiles have been installed.
- base plates — with a minimum wall thickness of 4 mm, positioned or fixed to any substrate. The head, the inverter, the couplers and the base plate are equipped with a safety interlocking system. The base diameter is 200 mm
- locking keys — to lock the pedestal at the required height. The Certificate holder states that the locking key has the function of blocking the post against involuntary unscrewing. Once the key is in place and the deck is mounted, the key can no longer be accessed and removed without disassembling the deck. Even if a key is lost, this has no effect on the durability and function of the post
- slope correctors — the U-PH5 slope corrector (0 to 5%) built into the head of pedestals and allows precise adjustment in increments of 0.5% if required. For some of the pedestals, it is integrated into the pedestal assembly, and for the remaining types, it can be fixed at the top of pedestal.

Figure 1 Components of BC Pedestal



The product has the nominal characteristics given in Table 1.

Table 1 Nominal characteristics and components of BC pedestals range.

Pedestal ID	Pedestal type	Characteristic (unit)			Components
		Height (mm)	Top plate, ϕ (mm)	Base plate, ϕ (mm)	
BC-0	Fixed	11	160	200	—
BC-1	Fixed	14	184	200	—
BC-02	Adjustable	28 - 40	145	200	BC top plate BC base plate
BC-2	Adjustable	40 - 55	145	200	BC top plate BC base plate
BC-3	Adjustable	55 - 85	145	200	BC top plate BC base plate
BC-4	Adjustable	85 - 140	145	200	BC top plate BC base plate
BC-5	Adjustable	116 - 200	145	200	BC top plate BC base plate
BC-6-INV	Adjustable	198 - 240	145	200	BC-4-NSC top plate BC-4-NCS base plate 1 BC-C4 inverter
BC-7	Adjustable	230 - 360	145	200	BC-5-NSC top plate BC-5-NCS base plate 1 BC-C3 coupler
BC-8-INV	Adjustable	342 - 465	145	200	BC-5-NSC top plate BC-5-NSC base plate BC-C4 inverter BC-C3 coupler
BC-9-INV	Adjustable	452 - 630	145	200	BC-5-NSC top plate BC-5-NSC base plate BC-C4 inverter 2 BC-C3 couplers
BC-10-INV	Adjustable	562 - 795	145	200	BC-5-NSC top plate BC-5-NSC base plate BC-C4 inverter 3 BC-C3 couplers
BC-11-INV	Adjustable	672 - 965	145	200	BC-5-NSC top plate BC-5-NSC base plate BC-C4 inverter 4 BC-C3 couplers
BC-12-INV	Adjustable	782 - 1130	145	200	BC-5-NSC top plate BC-5-NSC base plate BC-C4 inverter 5 BC-C3 couplers

Figure 2 BC Pedestals – Illustrations

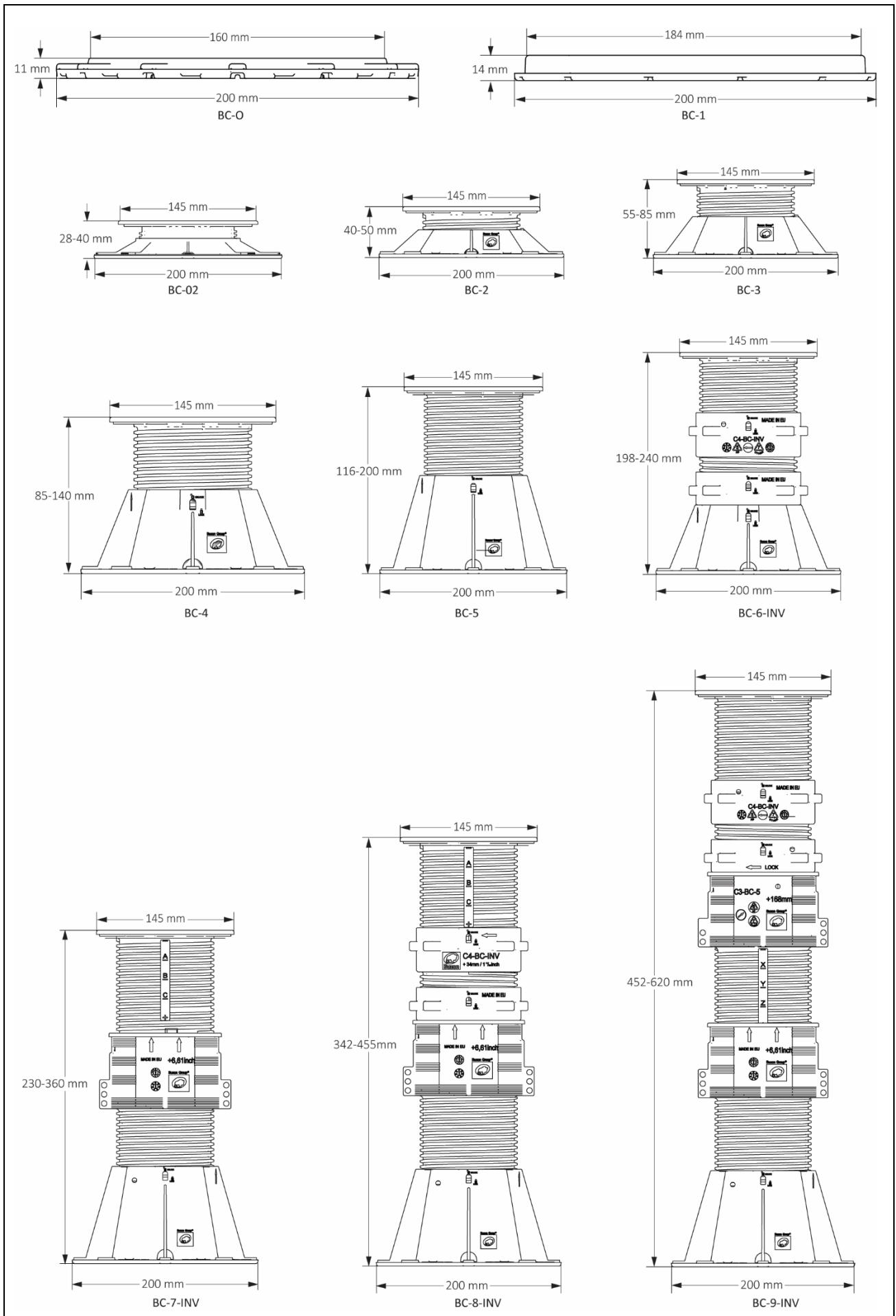
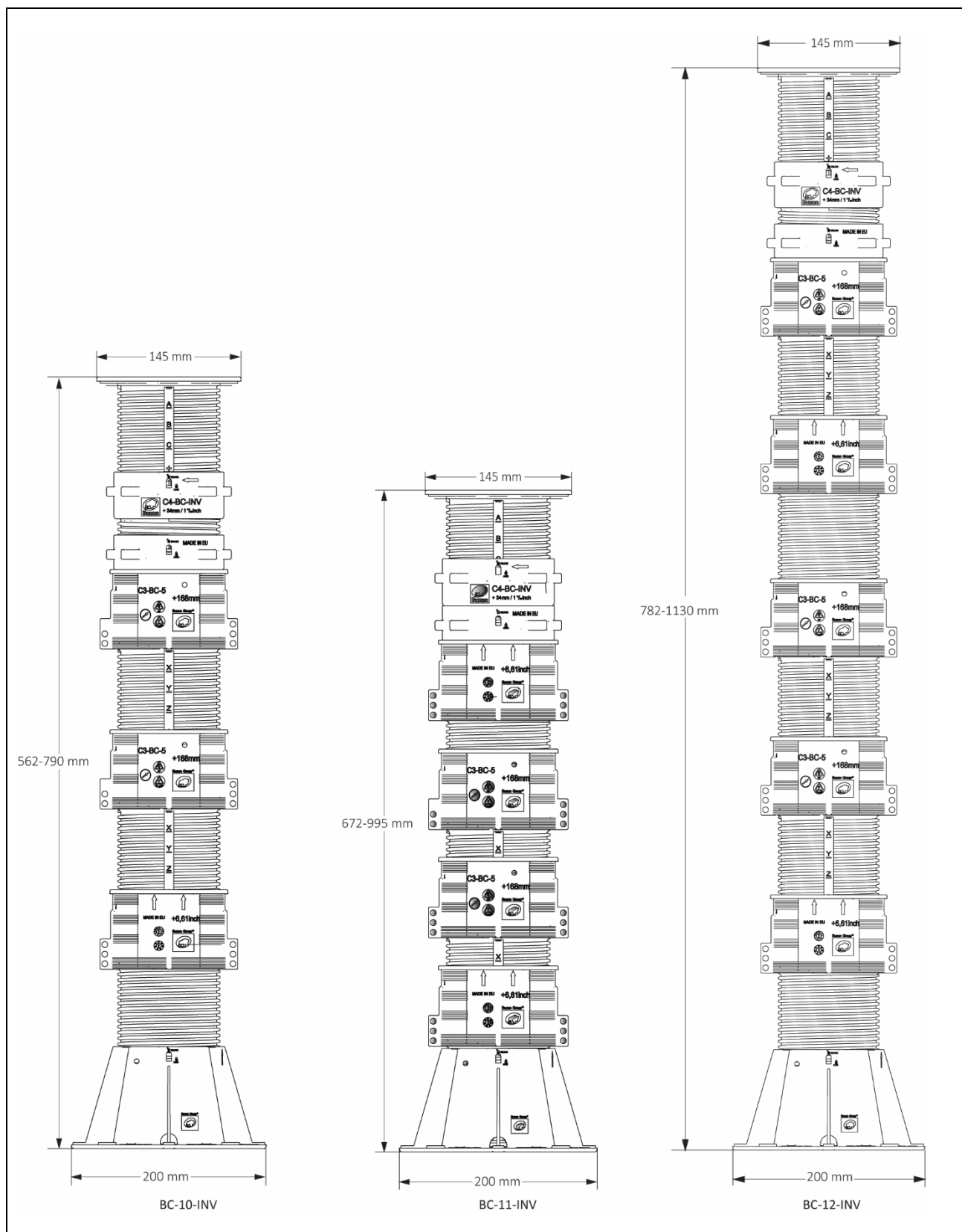

Figure 2 BC Pedestals – Illustrations (continued)



Ancillary Items

The Certificate holder recommends the following ancillary items for use with the product, but these materials have not been assessed by the BBA and are outside the scope of this Certificate:

- spacer tabs (see Figure 2) — available in thicknesses of 2, 3, 4.5, 6, 8 and 10 mm. Spacer tabs provide proper alignment of the pavers placed on top of the pedestals
- shims — to stabilise the paver, provide additional acoustic comfort, and compensate for variations in paver thickness. Shims are 1 or 2 mm thick with maltase-cross shaped levellers and are available as U-E10 or U-E20 (see Figure 3).
- batten holder — firmly holds the joists supporting the deck boards. There are two types: fixed (maximum size of batten is 65 mm) and universal (maximum size of batten up to 100 mm) (see Figure 4). The minimum thickness of the joist is 30 mm.

Figure 4 Shims

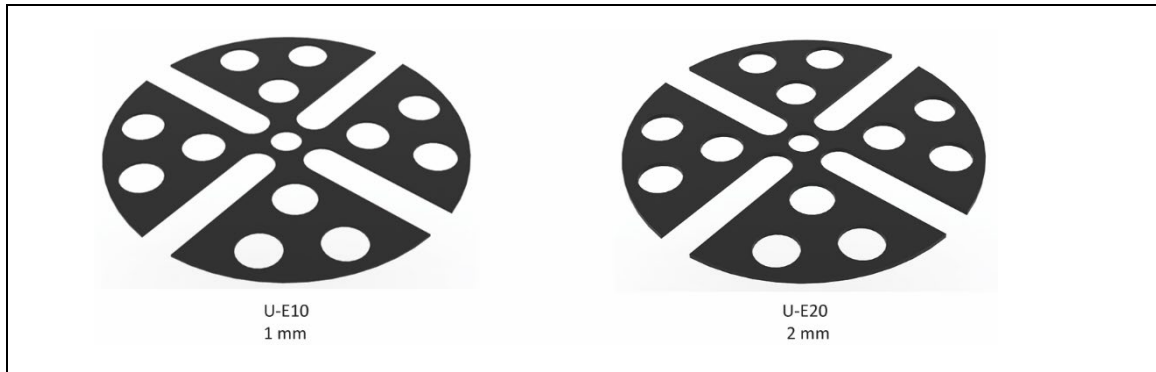

Figure 5 Batten holder



Definitions for products and applications inspected

The pedestals are not designed to support moving/vibratory machines or vehicular traffic and equipment, including maintenance, cleaning or vehicular traffic. The pedestals are designed for pedestrian use only.

Product assessment – key factors

The product was assessed for the following key factors, and the outcome of the assessment is shown below. Conclusions relating to the Building Regulations apply to the whole of the UK unless otherwise stated.

1 Mechanical resistance and stability

Data were assessed for the following characteristics.

1.1 Strength and stability

1.1.1 BC Pedestals were subjected to short-term compressive failure loads based on the specifications of EN 12825 : 2001. The loads were applied on the whole surface area of the pedestal (1/1). The compressive failure loads are summarized in Table 2 of this Certificate.

Table 2 BC Pedestals – short-term compressive failure load values at 23°C

Product assessed	Assessment method	Tested height (mm)	Requirement	Result ⁽¹⁾
				Failure Load at 23°C (kN) Test (1/1)
BC-0	Based on the specifications of EN 12825 : 2001	11	Value achieved	21.10
BC-1		14		91.45
BC-02		40		9.77
BC-2		55		13.92
BC-3		85		12.70
BC-4		140		13.60
BC-5		200		14.58
BC-6-INV		240		10.73
BC-7		360		13.72
BC-8-INV		465		10.53
BC-9-INV		630		10.18
BC-10-INV		795		10.34
BC-11-INV		965		9.45
BC-12-INV	1130	10.04		

(1) Maximum load per one pedestal not to exceed the value of 1/1.

1.1.2 On the basis of data assessed, the products have the short term failure compressive strengths as stated in Table 2. The values in Table 2 must be divided by a factor of 3 to find the characteristic resistance of each pedestal. The design compressive resistance is limited as defined in section 9.1.5.

1.2 Behaviour under loading

An evaluation of creep behaviour was assessed. The product is not deemed to deform non-uniformly due to creep behaviour.

2 Safety in case of fire

Data were assessed for the following characteristics.

2.1 External fire spread

2.1.1 When tested to DD CEN/TS 1187 : 2012, Test 4, the constructions given in Table 3 of this Certificate achieved a classification under BS EN 13501-5 : 2016 of B_{ROOF}(t4).

Table 3 External Fire Spread classifications

Product assessed			Assessment method	Reinforcement	Reaction to fire classification
Construction from base to top					
Supporting deck	Wood particle board	16 mm thickness 680 kg·m ⁻³ density	Tested to DD CEN/TS 1187 : 2012, Test 4 Reaction to fire classification to BS EN 13501-1 : 2016 ⁽¹⁾⁽²⁾	—	—
Vapour barrier	Self-adhesive bituminous air and vapour control layer with a polyester-coated aluminium foil and glass fleece reinforcement and a mineral finish	2.5 mm thickness 3000 g·m ⁻² surface weight		200 g·m ⁻² polyester-coated aluminium foil and 60 g·m ⁻² glass fleece	E
Adhesive	PUR adhesive	75 g·m ⁻² applied amount with twin cartridge applicator gun		—	—
Insulation layer	Polyisocyanurate (PIR) insulation boards with an aluminium facing and backing	120 mm thickness 30 kg·m ⁻³ density facing aluminium 37 g·m ⁻² backing aluminium 37 g·m ⁻²		—	E
Roof covering – first layer	Self-adhesive elastomeric underlayer with a glass lattice reinforcement	3 mm thickness 3500 g·m ⁻² surface weight		200 g·m ⁻² glass lattice	—
Roof covering – top layer	Torched-on elastomeric underlayer with a spunbond polyester reinforcement and a charcoal mineral finish	5.2 mm thickness 6500 g·m ⁻² surface weight		250 g·m ⁻² spunbond polyester	—
Pedestal system	PB-3 (loosely placed on the top layer) consisting of PB top, base, tabs 10 mm h17 and U-E20 SBR	90 mm height 170 mm top diameter 197 mm bottom diameter 492 g mass		—	B _{ROOF} (t4)
Ceramic tiles	Loosely laid onto the pedestals	20 mm thickness 417 x 417 mm and 835 x 417 mm 54000 g·m ⁻² surface weight		—	A1

(1) Fire test and classification reports, reference 20958A and 20958B respectively, conducted by Warringtonfire Gent. Reports are available from the Certificate holder.

(2) Fields of Application are included in the above reports:

Direct Field of Application:

- Range of roof pitches: ≤ 10°

- Deck: wood particle board (16 mm thick or more and 680 kg·m⁻³ density or more)

Extended Field of Application:

- Range of tiles: 20 mm thick or more, 10 mm or less joints, 54000 g·m⁻² surface weight and class A1 reaction to fire

- Range of pedestals can be 90 mm or more height.

2.1.2 On the basis of data assessed, when classified to BS EN 13501-5 : 2016, the construction incorporating the pedestals given in Table 3, achieved external fire classification B_{ROOF}(t4) for slopes below or equal to 10° and so, with the exceptions given in sections 2.2.2 to 2.2.4, are unrestricted in terms of proximity to a relevant boundary by the documents supporting the national Building Regulations. Restrictions may apply at junctions with compartment walls.

2.1.3 The classification and permissible areas of use of other specifications must be confirmed by reference to the requirements of the documents supporting the national Building Regulations.

2.2 Reaction to fire

2.2.1 The reaction to fire classification was tested in accordance with BS EN 13501-1 : 2019.

Table 4 Reaction to fire classification

Product assessed	Assessment method	Requirement	Result
Representative related product	DN EN 13501-1 : 2019	Value achieved	Class B _{fl} -s1 ⁽¹⁾

(1) Exova Warringtonfire Report no: 200579-K1, 30 June 2020. Copies can be obtained by the Certificate holder.

2.2.2 On the basis of data assessed, In Scotland, the product must not be used on balconies on buildings with a storey 11 m or more above the ground.

2.2.3 On the basis of data assessed, in England and Wales, the product must not be used on balconies on buildings that have a storey at least 18 m above ground level and which contain one or more dwellings, an institution, a room for residential purposes (excluding, in Wales only, any room in a hostel, hotel or boarding house), student accommodation, care homes, sheltered housing, hospitals or dormitories in boarding schools. Additionally, in England, the product must not be used on balconies of residential buildings with a storey 11 m or more in height.

2.2.4 On the basis of the data assessed, in Northern Ireland, the product must not be used on balconies on buildings that have a storey at least 18 m above ground level and which contain one or more dwellings, an institution, a room for residential purposes (excluding any room in a hostel, hotel or boarding house), student accommodation, care homes, nursing homes, sheltered housing, hospitals, dormitories in boarding schools and places of lawful detention.

3 Hygiene, health and the environment

Data were assessed for the following characteristics.

3.1 Resistance to chemicals

3.1.1 The material representative samples were stored in accordance with ASTM D 543-14 and were subjected to tensile tests in accordance with DIN EN ISO 527-1 : 2012-06, the changes in volume, mass and dimensions were also measured. The density was measured in accordance with DIN EN ISO 1182 : 2013-04. The results are given in Tables 5 and 6 of this Certificate.

Table 5 Tensile properties

Material assessed	Assessment method	Requirement	Result ⁽¹⁾
Recycled copolymer polypropylene (CPP)	DIN EN ISO 527-1 : 2012-06	Value achieved	Tensile modulus 2040 ± 25 MPa
			Tensile stress 18.9 ± 0.7 MPa
	Control sample		Elongation at break 18.5 ± 5.8 (%)
DIN EN ISO 527-1 : 2012-06	(7 days at 50°C in 3% Sulfuric acid)	Value achieved	Tensile modulus 1970 ± 31 MPa
			Tensile stress 18.9 ± 0.7 MPa
			Elongation at break 20.3 ± 6.7 (%)
DIN EN ISO 527-1 : 2012-06	(7 days at 50°C in 10% Sodium Chloride)	Value achieved	Tensile modulus 1960 ± 23 MPa
			Tensile stress 19.3 ± 0.5 MPa
			Elongation at break 18.9 ± 5.3 (%)
DIN EN ISO 527-1 : 2012-06	(7 days at 50°C in 5% Sodium Hypochlorite)	Value achieved	Tensile modulus 1920 ± 19 MPa
			Tensile stress 19.4 ± 0.4 MPa
			Elongation at break 14.1 ± 2.5 (%)

(1) Mean values ± standard deviation

Table 6 Dimensional stability

Product assessed	Assessment method	Requirement	Result (%) ⁽¹⁾
Recycled copolymer polypropylene (CPP)	ASTM D543-14 (7 days at 50°C in 3% Sulfuric acid)	Value achieved	Thickness
			-0.04 ± 0.07
			Width
			0.13 ± 0.16
			Weight change
			0.24 ± 0.09
			Volume change
			0.25 ± 0.15
Recycled copolymer polypropylene (CPP)	ASTM D543-14 (7 days at 50°C in 10% Sodium Chloride)	Value achieved	Thickness
			-0.27 ± 0.38
			Width
			0.1 ± 0.1
			Weight change
			0.21 ± 0.31
			Volume change
			0.19 ± 0.41
Recycled copolymer polypropylene (CPP)	ASTM D543-14 (7 days at 50°C in 5% Sodium Hypochlorite)	Value achieved	Thickness
			-0.12 ± 0.31
			Width
			0.07 ± 0.15
			Weight change
			0.23 ± 0.16
			Volume change
			0.27 ± 0.15

(1) Mean values ± standard deviation.

3.1.3 On the basis of data assessed, all tested chemicals caused only minor variation in dimension, weight and volume. Storage in all chemicals caused no changes in appearance visible to the naked eye.

4 Safety and accessibility in use

Not applicable.

5 Protection against noise

Not applicable.

6 Energy economy and heat retention

Not applicable.

7 Sustainable use of natural resources

Data were assessed for the following characteristics.

7.1 Reuse and recyclability

The product is manufactured from CPP, which can be recycled.

8 Durability

8.1 The potential mechanisms for degradation and the known performance characteristics of the materials in the product were assessed.

8.2 Service life

Under normal service conditions, the product will have a life in excess of 30 years, provided it is designed, installed and maintained in accordance with this Certificate and the Certificate holder's instructions.

PROCESS ASSESSMENT

Information provided by the Certificate holder was assessed for the following factors:

9 Design, installation, workmanship and maintenance

9.1 Design

9.1.1 The design process was assessed by the BBA and the following requirements apply in order to satisfy the performance specified in this Certificate.

9.1.2 Designers, planners, contractors and/or installers must ensure that the installation of BC Pedestals is in accordance with the Certificate holder's instructions and the information given in this Certificate.

9.1.3 The suitability of the floor/deck to support the loads and the expected displacement in both the short- and long-term must be considered by a suitably experienced and competent individual.

9.1.4 It is a responsibility of the designer to ensure that the pedestals are not cut in any situation.

9.1.5 A suitably experienced and competent individual must undertake the calculations to the relevant code of practice, including:

- the characteristic values of the imposed loads for flat roofs, balconies, terraces and porches in accordance with BS EN 1991-1-1 : 2002 and its UK National Annex, and the characteristic values of the imposed loads for areas of industrial use in accordance with PD 6688-1-1 : 2011
- the characteristic values of the self-weight and finishes for floors, roofs, balconies in accordance with BS EN 1991-1-1 : 2002 and its UK National Annex
- the ultimate load applied on each pedestal in accordance with either equation 6.10 or less favourable equations 6.10a and 6.10b of BS EN 1990 : 2023 and its UK National Annex based on self-weight of the floor and finishes, and imposed loads as defined in first and second bullet points mentioned above
- the design compression load applied on each pedestal must not exceed 3.3 kN for 1/1 BC pedestal as defined in section 1.1.1 of this Certificate, and the failure loads applied on each pedestal must not exceed the values defined in Table 2 of this Certificate
- take into account the short- and long-term displacement of each pedestal mentioned in Table 1 of this Certificate. Also, take into account the short and long-term deflection of substrates

- an assessment of the robustness of the design to ensure if any locking key, positioned at one corner of a slab, inadvertently was unlocked due to foreseen or unforeseen events (incorrect installation, impact, or survival after an accidental event) to prevent collapse of the floor or roof or balcony.

9.2 Installation

9.2.1 Installation instructions provided by the Certificate holder were assessed and judged to be appropriate and adequate.

9.2.2 Installation must be carried out in accordance with this Certificate and the Certificate holder's instructions. A summary of instructions and guidance is provided in Annex A of this Certificate.

9.2.3 BC Pedestals must be transported in their original packaging. It must be ensured that no damage occurs during transport and the pedestal components must be checked before installation. Also, they must be handled with care during installation and to avoid damage by being dropped.

9.3 Workmanship

Practicability of installation was assessed by the BBA on the basis of the Certificate holder's information and a site visit to witness an installation in progress. To achieve the performance described in this Certificate, installation of the product must be carried out by a competent general builder, or a contractor experienced with this type of product.

9.4 Maintenance and repair

9.4.1 As the product is confined within the floor void and has suitable durability. Maintenance is not required.

The following requirements apply in order to satisfy the performance assessed in this Certificate:

9.4.2 The pedestals are manufactured from CPP and do not require maintenance in general.

9.4.3 If the pedestals need to be replaced, the guidelines provided in the Certificate holder's manual must be followed.

10 Manufacture

10.1 The production processes for the product have been assessed, and provide assurance that the quality controls are satisfactory according to the following factors:

10.1.1 The manufacturer has provided documented information on the materials, processes, testing and control factors.

10.1.2 The quality control operated over batches of incoming materials has been assessed and deemed appropriate and adequate.

10.1.3 The quality control procedures and product testing to be undertaken have been assessed and deemed appropriate and adequate.

10.1.4 The process for management of non-conformities has been assessed and deemed appropriate and adequate.

10.1.5 An audit of each production location was undertaken, and it was confirmed that the production process was in accordance with the documented process, and that equipment has been properly tested and calibrated.

† 10.2 The BBA has undertaken to review the above measures on a regular basis through a surveillance process, to verify that the specifications and quality control operated by the manufacturer are being maintained.

11 Delivery and site handling

11.1 The Certificate holder stated that the product is delivered to site in packaging bearing the details of components including type and dimensions, and the BBA logo incorporating the number of this Certificate.

Supporting information in this Annex is relevant to the product but has not formed part of the material assessed for the Certificate.

Construction (Design and Management) Regulations 2015

Construction (Design and Management) Regulations (Northern Ireland) 2016

Information in this Certificate may assist the client, designer (including Principal Designer) and contractor (including Principal Contractor) to address their obligations under these Regulations.

Management Systems Certification for production

The management system of the manufacturer has been assessed and registered as meeting the requirements of BS EN ISO 9001 : 2015 by SGS (Certificate BE 18/819943236)

Additional information on installation

A.1 Good site practice must be observed to prevent damage to the components of the pedestal.

A.2 BC pedestals can be installed on a wide range of solid, even and stable substrates, such as concrete slabs, cement screeds, waterproof membranes and insulation panels. Substrates must be free of dust, dirt and waste material. Use of wedges under pedestals must be avoided. The designer must confirm layout, position and height of the decking or pavers. Installation must be strictly in accordance with the Certificate's holder's Installation Manual.

A.3 For installation, mason wire is used to set out the first line, and a second line, perpendicular to the first. Chalk can be used to draw lines on the substrate. After setting out the initial two lines, grid lines can be extended to mark the location of the pedestals. The dimensions of grid lines depend on the dimensions of the paver used. Further guidelines may be found in Certificate holder's Installation Manual.

A.4 Three pedestals need to be placed at the junction of the two initially drawn lines, and checked with a leveller to ensure the heads of the pedestals are at the same height and level (see Figure 5.1). If necessary, accessories such as spacer tabs or shims can be used, such as to compensate for the variation in paver thickness. The paver is then balanced and levelled on the three pedestals (see Figure 5.2).

A.5 A fourth pedestal can then be inserted (see Figure 5.3) and its head level checked. The pedestal's head and paver must be perfectly level.

Figure 6 Pedestal installation

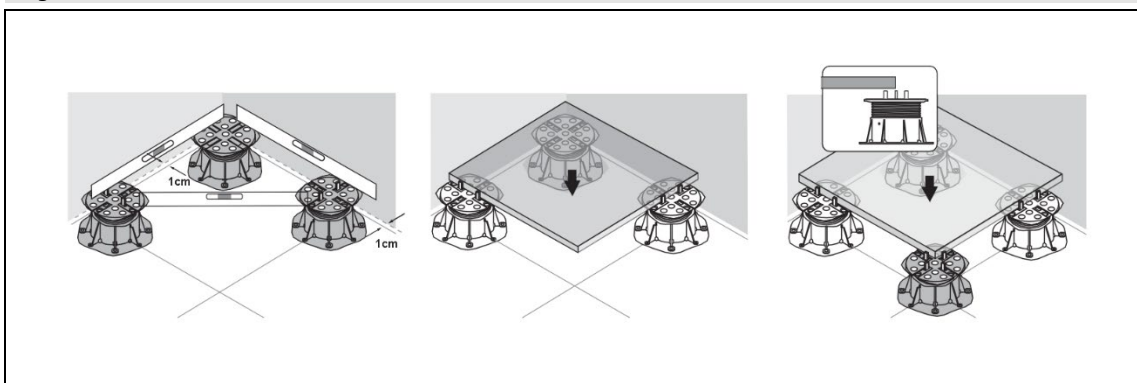

A.6 With the first paver installed, the next pedestal must be placed (in line with the first paver). The level is checked for the two most recently placed pedestals under the first paver, and the newly placed pedestal (as shown in Figure 7). The second paver is then balanced on the three checked pedestals, with the information in sections A.5 and A.6 followed regarding levelling and the placement of the fourth pedestal. In the same manner, all pavers are placed along the wall, ensuring all pavers are level. If pavers are not level, accessories mentioned in the *Product description and intended use* section of this Certificate may be used.

Figure 7 Pedestal installation cont.

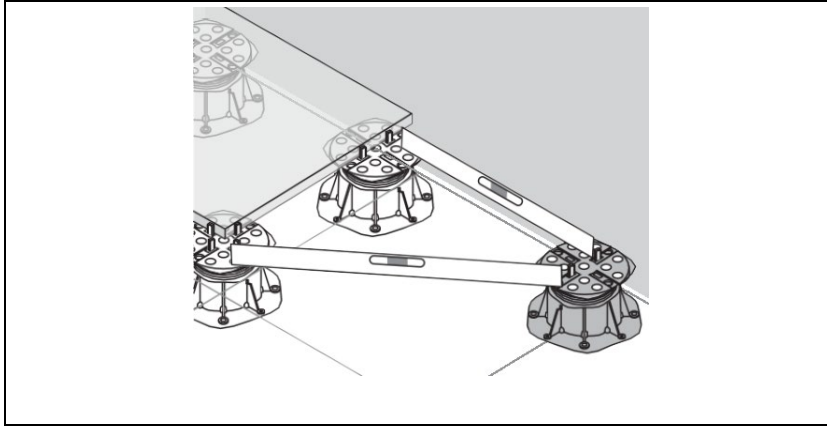

A.7 With the completion of the first row of pavers, another row, perpendicular to the first row, must be executed in the same manner as described previously. Further details can be found in the Certificate holder's Installation Manual.

A.8 If the design demands a slope, the slope corrector can be fixed on the pedestal. The direction of the slope is marked on the floor with chalk. Spacer tabs and shims can be used with the product if needed. Further details can be requested from the Certificate holder.

A.9 Typically, four pedestals placed at the edges are used to support each paver. If needed, one extra pedestal in the middle of the paver may be used for improved stability. In the case of large pavers, it is recommended to use the extra pedestal. Installation must be in accordance with the installation manual from the paver manufacturer.

A.10 If wood is used for the system, then batten holders need to be used. The type of batten holder will depend on the dimension of wood joist or batten used. Wood joists or battens placed on pedestals need to be fixed with screws.

A.11 After installation of each paver, the alignment must be checked.

A.12 Installation must be in accordance with the Certificate holder's instructions and this Certificate.

Bibliography

ASTM D 543-14 *Standard Practices For Evaluation The Resistance Of Plastics To Chemical Reagents*

BS EN 1990 : 2023 *Eurocode — Basis of structural and geotechnical design*

UK to BS EN 1990 : 2023 UK National Annex to *Eurocode — Basis of structural and geotechnical design*

BS EN 1991-1-1 : 2002 *Eurocode 1 — Actions on structures — General actions — Densities, self-weight, imposed loads for buildings*

NA to BS EN 1991-1-1 : 2002 UK National Annex to *Eurocode 1 — Actions on structures — General actions — Densities, self-weight, imposed loads for buildings*

BS EN 13501-1 : 2007 *Fire classification of construction products and building elements — Classification using data from reaction to fire tests*

BS EN 13501-5 : 2016 *Fire classification of construction products and building elements — Classification using data from external fire exposure to roofs tests*

BS EN ISO 9001 : 2015 *Quality management systems — Requirements*

DIN EN ISO 527-1 : 2012-06 *Plastics — Determination of tensile properties — General principles*

DIN EN ISO 1182 : 2013-04 *Reaction to fire tests for products — Non-combustibility test*

DD CEN/TS 1187 : 2012 *Test methods for external fire exposure to roofs*

EN 12825 : 2001 *Raised access floors*

PD 6688-1-1 : 2011 *Recommendations for the design of structures to BS EN 1991-1-1*

Conditions

1 This Certificate:

- relates only to the product that is named and described on the front page
- is issued only to the company, firm, organisation or person named on the front page – no other company, firm, organisation or person may hold or claim that this Certificate has been issued to them
- has to be read, considered and used as a whole document – it may be misleading and will be incomplete to be selective
- is copyright of the BBA
- and any matter arising out of or in connection with it or its subject matter (including non-contractual disputes or claims) is governed by and construed in accordance with the law of England and Wales.
- the courts of England and Wales shall have exclusive jurisdiction to settle any matter arising out of or in connection with this Certificate or its subject matter (including non-contractual disputes or claims).

2 Publications, documents, specifications, legislation, regulations, standards and the like referenced in this Certificate are those that were current and/or deemed relevant by the BBA at the date of issue or reissue of this Certificate.

3 This Certificate will be displayed on the BBA website, and the Certificate Holder is entitled to use the Certificate and Certificate logo, provided that the product and its manufacture and/or fabrication, including all related and relevant parts and processes thereof:

- are maintained at or above the levels which have been assessed and found to be satisfactory by the BBA
- continue to be checked as and when deemed appropriate by the BBA under arrangements that it will determine
- are reviewed by the BBA as and when it considers appropriate.

4 The BBA has used due skill, care and diligence in preparing this Certificate, but no warranty is provided.

5 In issuing this Certificate the BBA is not responsible and is excluded from any liability to any company, firm, organisation or person, for any matters arising directly or indirectly from:

- the presence or absence of any patent, intellectual property or similar rights subsisting in the product or any other product
- the right of the Certificate holder to manufacture, supply, install, maintain or market the product
- actual installations of the product, including their nature, design, methods, performance, workmanship and maintenance
- any works and constructions in which the product is installed, including their nature, design, methods, performance, workmanship and maintenance
- any loss or damage, including personal injury, howsoever caused by the product, including its manufacture, supply, installation, use, maintenance and removal
- any claims by the manufacturer relating to UKCA marking and CE marking.

6 Any information relating to the manufacture, supply, installation, use, maintenance and removal of this product which is contained or referred to in this Certificate is the minimum required to be met when the product is manufactured, supplied, installed, used, maintained and removed. It does not purport in any way to restate the requirements of the Health and Safety at Work etc. Act 1974, or of any other statutory, common law or other duty which may exist at the date of issue or reissue of this Certificate; nor is conformity with such information to be taken as satisfying the requirements of the 1974 Act or of any statutory, common law or other duty of care.